

High current technology • Flexible connectors •
Solderless cable connection technology • Electroplating equipment

druseidt

Elektrotechnik

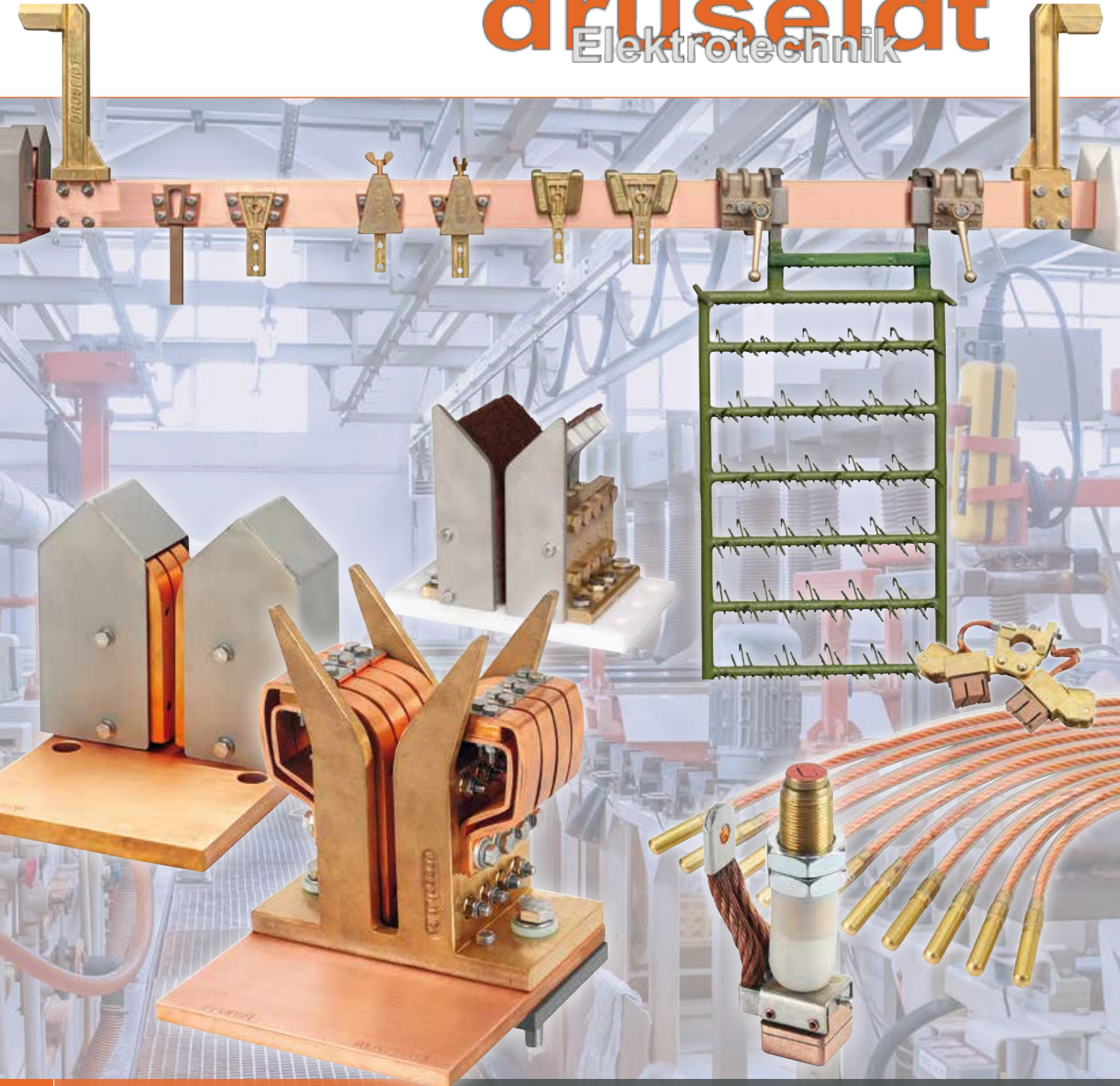

Catalogue No. 3

Contact systems and accessories for anodizing
and electroplating plants





© Catalogue 3
Contact systems and accessories for anodizing
and electroplating plants
1. Edition 2022

Paul Druseidt
Elektrotechnische Spezialfabrik GmbH & Co. KG
Neuenkamper Straße 105
42855 Remscheid, Germany

Phone: +49 (21 91) 93 52-0
Fax: +49 (21 91) 93 52-150
http: www.druseidt.de
E-Mail: info@druseidt.de

The dimensions and technical data listed in this catalogue have been determined with the greatest possible care and the illustrations correspond to the status at the time of printing. However, we reserve the right to make technical changes as well as changes in dimensions, shape and colour.

Our specifications, in particular the values for possible current loads, are non-binding guide values. The assignment of conductor cross-sections, of current carrying capacities by national or international standards or regulations is neither restricted nor cancelled by this. Only the details and commitments in our order confirmations are binding for us.

The use of photos, drawings, catalogue pages etc. for own advertising campaigns or other uses requires or formerly written acceptance.

Contact-systems and accessories for anodizing and electroplating plants

Electroplating baths with high current densities are high energy consumers. Ensuring a permanently high quality of the coating, saving energy, increasing plant availability, shortening cycle times and thus increasing productivity and reducing costs are therefore the essential requirements placed on a modern electroplating or anodizing plant today.

Power supply lines and electrical contacts are responsible to a considerable extent for both, the generation of electrical power loss and repair related plant down time. They are not only subject to high electrical but also mechanical and chemical stresses.

druseidt has been developing and manufacturing contact systems and current transfer elements for anodizing and electroplating systems for decades and knows the problems from practical experience. Therefore contact systems are constantly being redeveloped or improved to meet the increased technical requirements. Additionally the problem of contamination of contacts and product carriers was also included in the development of an overall concept to reduce energy losses and increase system availability.

druseidt delivery and service offer

We offer comprehensive support in the design, new construction or repair of electroplating and anodizing plants and deliver:

- Contact systems for contacting product carriers within rack systems
- Cleaning saddles and accessories for the cleaning of contacts and product carriers
- Contacts for galvanizing racks
- Contacts for anode bars and support blocks
- Complete product carriers
- Contacts and accessories for electroplating barrel systems
- Flexible cables and current transfer elements
- Contact systems for rotating current collectors
- Special customized solutions
- Design and supply of complete busbar systems or busbar components



We supply contact systems for the contacting of product carriers for almost all application

Why are different contact systems offered?

It is simply because there are a multitude of different system concepts and designs on the market. It is therefore not possible to develop a contact series that is equally suitable for all systems or can be used everywhere.

The shape, weight and design of the product carriers are extremely varied. In addition to rectangular or H-shaped contact points, there are also profiles at the ends of the product carriers. Also extremely light or particularly heavy carriers, all of which require an appropriately designed contact adapted to the conditions. The chemical stresses or the degree of contamination of systems can also be extremely different and must be taken into account. Last but not least, the space available for the installation of contacts also play a not inconsiderable role. Often a standard solution cannot be used and the contacts have to be customized.

What kind of contact saddle is now suitable for what kind of application?

Unfortunately, this question cannot be answered in a general way. As already mentioned above, the contacts must be adapted to the installation situations and requirements of the different plants. Important criteria for the selection are therefore:

- The current load
- The cycle time/duration of the current load
- The current feed (symmetrical/unsymmetrical)
- Weight and dimension of the product carriers
- Shape and dimensions of the contact points of the product carriers
- Expected chemical influences and contamination
- Possible mechanical stress
- Any existing bath movements
- Available installation space

Please also note to our recommendations for the dimensioning of contacts within electroplating and anodizing plants. You find it in the technical appendix on page 79 of this catalogue.

druseidt contact saddle systems

Different systems for different plants offer the user individually adapted solutions

Which druseidt contact saddles for rack systems are available as standard?

In order to be able to cover as many applications as possible, druseidt supplies various series of standard contact saddles. Here we offer the following systems:

druseidt finger contact systems



- One or two-part version for current load up to 14000 A
- With integrated insertion guide for current load up to 4000 A
- For clamping of product carriers of different thickness without the need to change the setting for current load up to 5000 A
- For test and laboratory facilities for current load up to 500 A
- Finger contact modules for current load up to 600 A

druseidt bolt contact systems

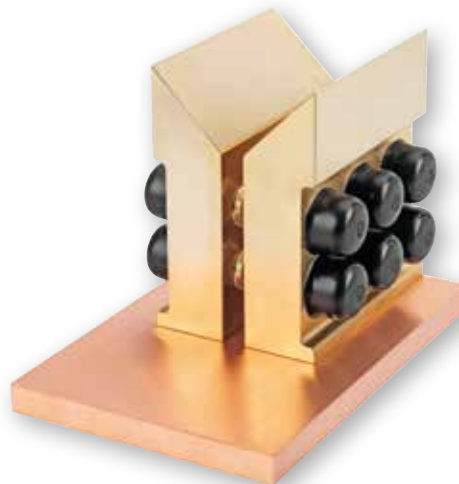

- Bolt contact modules for current load up to 1250 A
- Bolt contacts for current load up to 12000 A
- Pneumatically actuated bolt contacts for current load up to 6000 A or more

druseidt hydro-pneumatically actuated contact systems



- Titan system in standard design for current load up to 5000 A
- Titan system with dimensional difference compensation for current load up to 15000 A or more

druseidt pneumatically actuated plate contact systems



- Compact model 2500 for current load up to 3000 A
- Compact model 3000 with optional water cooling for current load up to 12000 A and more

Table of content

Article		Page
High current contacts and accessories for rack systems		
Finger contact saddles one-piece standard design	250 - 3000 A	8 - 9
Finger contact saddles two-piece design	4000 - 14000 A	10 - 11
Finger contact saddles with integrated insertion guide	250 - 4000 A	12 - 13
Finger contact saddles for clamping of product carriers of different thickness without the need to change setting	500 - 5000 A	14 - 17
Finger contact saddles for test and laboratory facilities	250 - 500 A	18
Finger contact modules	400 - 600 A	18
Bolt contacts	800 - 12000 A	19 - 20
Bolt contact modules	400 - 1250 A	19 - 20
Pneumatically actuated bolt contacts	800 - 6000 A	21 - 23
Pneumatically actuated switching units	1500 - 6000 A	24 - 25
Cleaning saddles dimensionally coordinated for parallel use of the bolt contacts		26
Hydro-pneumatically actuated contact saddles	3000 - 15000 A	27 - 36
Pneumatically actuated plate contacts	1500 - 12000 A	37 - 41
Controller modules for pneumatically actuated contact systems		42
Cleaning systems for finger contacts and product carriers		43 - 48
Anode busbar contacts		49
Support blocks		50
Off-, change-over and pole changing switches		51
Production of product carriers		52
Design and production of busbar systems		53
Contacts for plating racks		
Contact rack heads and holders		54/55
Safety clamps for contact rack heads		55
Eccentric clamping device		55
Quick release clamps		56 - 57
Contacts and accessories for electroplating barrel units		
Suspended galvanizing barrel units		58 - 59
Contact cables for electroplating barrels		60
Contacts for round shaped bolts		61
Contactors for barrel current		62
Contact systems for rotating collectors		
Carbone brushes and holders		63 - 67
Highly flexible solderless crimped connectors		
Braided connectors		68 - 69
Stranded connectors		70 - 71
Mounting accessories		
Standoff insulators		72 - 74
Bimetallic sheets, cut-offs and washers		75
Screwing materials		76 - 77
Copper paste and cleaning sprays		78
Cup wing nuts and bolts		78
Small brass contacts		78
Technical Appendix		
		79 - 82

Finger contact saddle systems

Designs and current loads

We design and manufacture high current finger contact saddle systems in various standard designs, both with and without protective covers made of stainless steel.

- One-piece standard design 250 A - 3000 A
- Two-piece standard design 4000 A - 14000 A
- One-piece models with integrated insertion guides 250 A - 4000 A
- For clamping of busbars of different thickness without the need to change the contact setting 500 A - 5000 A
- For test and laboratory facilities 250 A - 500 A
- Finger contact modules 400 A - 600 A

Advantages and design features

- **Self-tensioning:**
Insertion of product carriers using their own weight and therefore suitable for fully automatic system operation.
- **Self-cleaning:**
The contact surfaces are cleaned as far as possible by abrasion when the product carriers slide in.
- **Conductive:**
Contact fingers and foil packages are made of E-Copper with highest degree of conductivity.
- **Robust:**
Stable support structures of red bronze or brass and stable stainless steel protective covers.
- **Compact:**
Small installation dimensions even for contacts with high current rates.
- **Maintenance friendly:**
Easy interchangeability of individual parts. Manufactured according to the modular principle. This means that both, complete replacements contact elements or only individual foil packages can be exchange.



High current finger contact saddles 250 - 3000 A

One-piece standard design

Druseidt contact system proven for decades. Available both as one-piece standard contact saddles up to 20 mm product carrier thickness and as ready-to-mount contact unit directly equipped with a complete substructure, i. e. integrated E-copper plate or contact angle and, if required, additional insulating plate. The designs with protective covers made out of stainless steel A4 protect the contacts from acid and alkali splashes.

Protective covers in heavy duty design have an additional integrated 10 mm thick stainless steel busbar guide and are particularly recommended when working with heavy product carriers. This conductor rail insertion safely catches the product carrier and allows it to slide into the contact without any problems. As an alternative the retrofittable busbar guide Part-No. 50732 made of red bronze can be used when using contacts with normal protective covers or contacts without protective covers.



Standard finger contact saddles



Finger contact saddle ready for assembly with substructure and additional mounted busbar guide



Finger contact saddle with mounted stainless steel protective cover



Replacement contact elements and replacement foils

Please also note our cleaning systems matched to our contacts according to the catalogue pages 43 - 48.

High current finger contact saddles 250 - 3000 A

One-piece standard design

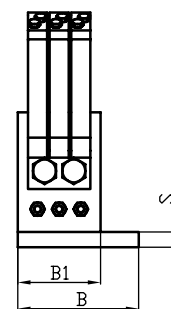
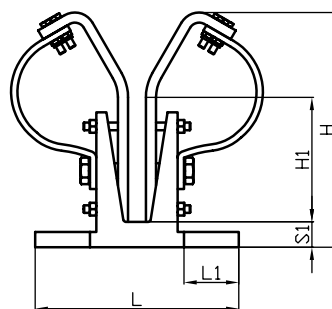
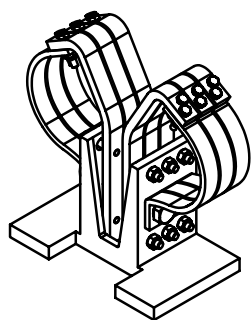

Part-No.			Technical data											
contact saddle without stainless steel protective covers	contact saddle with stainless steel protective covers	1 set prefabricated replacement contact elements	max. current load	suitable product carrier height mm	No. of contact fingers 15 x 8 mm	dimensions mm								weight kg/pcs without protective covers
						L	L ₁	B	B ₁	H	H ₁	S	S ₁	
50235	50237	30620	250 A	40 - 60	4	160	35	75	45	150	60	10	20	2,90
17080	17082	17160	250 A	80 - 120	4	160	35	75	45	180	85	10	20	3,10
50245	50247	30622	500 A	40 - 60	6	160	40	95	65	150	60	12	20	4,80
17085	17087	17165	500 A	80 - 120	6	160	40	95	65	180	85	12	20	5,00
50265	50267	30626	1000 A	40 - 60	6	160	40	95	65	150	60	12	20	5,20
17090	17092	17170	1000 A	80 - 120	6	160	40	95	65	180	85	12	20	5,40
50285	50287	30630	1500 A	40 - 60	6	160	40	95	65	150	60	12	20	5,60
17095	17097	17175	1500 A	80 - 120	6	160	40	95	65	180	85	12	20	5,80
17100	17102	17180	2000 A	80 - 120	8	160	40	80	-	180	85	12	20	6,80
17105	17107	17185	2500 A	80 - 120	10	195	50	100	-	180	85	14	20	8,00
17110	17112	17190	3000 A	80 - 120	14	230	55	135	-	180	85	16	20	13,50
17115	17117	17195	3000 A	100 - 150	14	230	55	135	-	210	110	16	20	13,60
50315	50317	30636	3000 A	120 - 200	14	230	55	135	-	240	135	16	20	14,70

Accessories/spare parts

50732 1 piece mounted insertion guide

17198 2-fold replacement foils

17199 3-fold replacement foils

30690 Replacement springs - stainless steel, standard

30691 Replacement springs - stainless steel, heavy version

Note: All dimensions in the table are without installed protective covers. The versions with fitted protective covers include protective covers in standard design acc. to the following table. Ready to install versions with substructure on request. All contact saddles are manufactured according to the modular principle so that individual foils as well as complete contact elements (contact fingers, foils and screw-on material) can be replaced. Contact saddles for a product carrier thickness of up to 20 mm are factory set as a one-piece model.

For thicker product carriers, the contact can be supplied separately in 2 halves. **When ordering, please indicate the thickness and height of the product carrier. The product carrier thickness is also required when ordering replacement contact elements, as the lengths of the grub screws to be installed depend on it.** For lighter product carriers (weight less than 50 kg) please contact us again, because the contact saddles must be set up accordingly.

Protective covers

Material: stainless steel A4,

suitable for contact saddles 250 - 3000 A

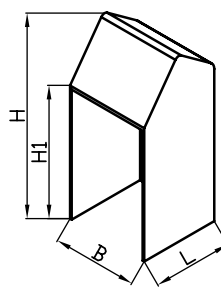

Standard design

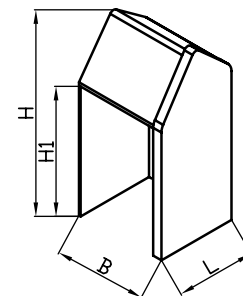

Heavy duty design

Part-No.		Technical data						
Protective covers standard design	Protective covers heavy duty design	suitable for contact saddle load	Part-No.	dimensions mm				
				L	B	H	H ₁	
30655	30655 vst	250 A	50235	85	50	165	110	
30656	30656 vst	250 A	17080	85	50	195	140	
30657	30657 vst	500 - 1500 A	50245/65/85	85	70	165	110	
30658	30658 vst	500 - 1500 A	17085/90/95	85	70	195	140	
30668	30668 vst	2000 A	17100	85	85	195	140	
30670	30670 vst	2500 A	17105	95	105	195	140	
31672	31672 vst	3000 A	17110	115	140	195	140	
32672	32672 vst	3000 A	17115	115	140	225	170	
30672	30672 vst	3000 A	50315	115	140	255	200	

Note: Protective covers in heavy duty design are equipped with an additional 10 mm thick stainless steel guide and recommended especially for heavier product carriers. The height of this design is 15 mm and the width 8 mm more than the dimensions of the standard designs described in the table.

When ordering protective covers for existing contact saddles at a later date, please also state the product carrier thickness or the delivery data of the contacts as the fixing holes on the covers must be positioned accordingly.

High current finger contact saddles 4000 - 14000 A

Two-piece model

Proven series for many years for currents from 4000 A. The standard version is supplied as a pair of contact halves that are not connected to each other. The assembly/adjustment is then individually matched to the existing product carrier dimension. The installation of the contact halves must be done with pretension, i.e. the mounting distance of the contact halves must be less than the thickness of the product carrier (depending on the contact saddle and the weight of the product carrier/consultation required). The slide of the product carrier into the contact is caused by its own weight, so that the contacts are ideally suited for fully automatic operation.

When the product carrier slides in, an additional self-cleaning effect is achieved through abrasion on the contact surfaces. Delivery as ready-to-mount contact unit mounted on a copper plate or -angle and possibly necessary insulating plate on request. To improve the mechanical stability and as protection against acid and alkali splashes, we recommend to use our A4 stainless steel protective covers. All contact saddles are manufactured according to the modular principle. Standard spare parts include complete replacement contact elements (contact fingers with mounted foils and all necessary screw accessories) as well as individual replacement foils.

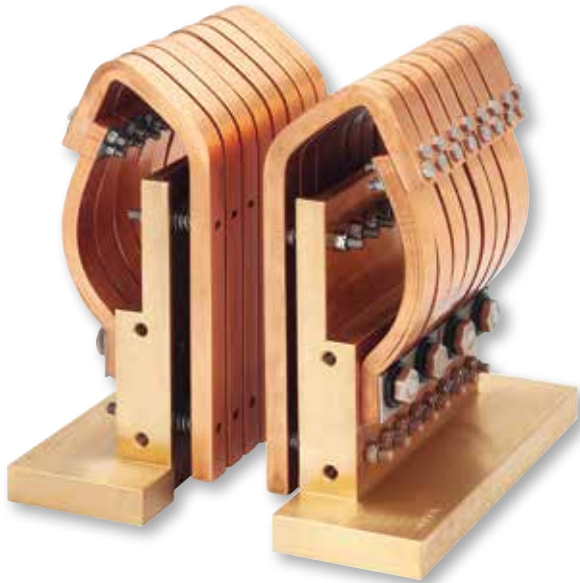

Standard contact saddle two-piece model

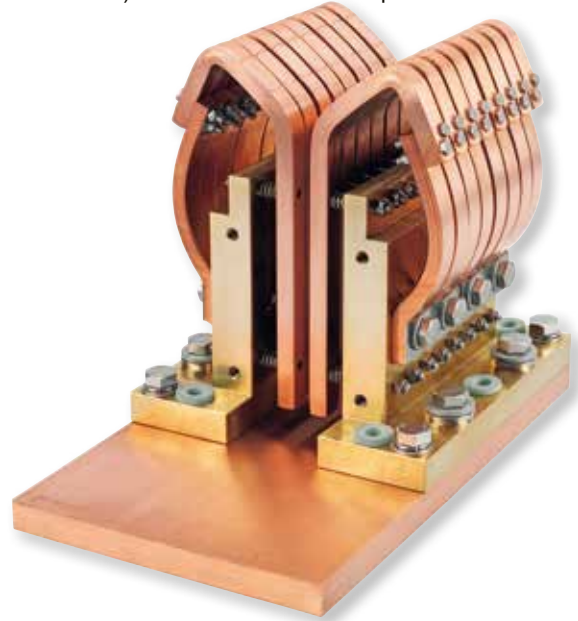

Ready-to-mount contact saddle with substructure



Contact saddle with mounted protective covers



Replacement contact elements / replacement foils

Please also note our cleaning systems matched to our contacts according to the catalogue pages 43-48.

High current finger contact saddles 4000 - 14000 A

Two-piece model

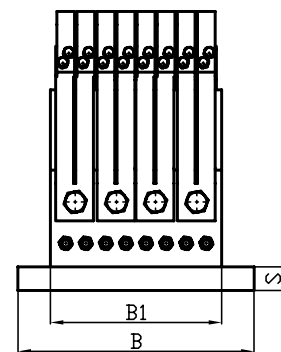
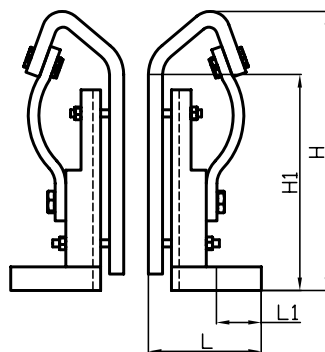
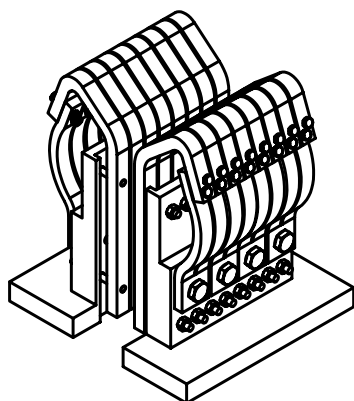

Part-No.			Technical data											
contact saddle without stainless steel protective covers	contact saddle with stainless steel protective covers	1 set prefabricated replacement contact elements	max. current load	suitable for product carrier height mm	No. of contact fingers 15 x 12 mm	dimensions mm								weight kg/pcs without protective covers
20011	20013	17371	4000 A	160 - 250	14	L	L ₁	B	B ₁	H	H ₁	S		
20022	20024	17381	6000 A	160 - 250	16	95	35	200	145	240	180	20	25,80	
20033	20035	17391	7000 A	160 - 250	20	95	35	230	175	240	180	20	30,20	
20044	20046	17401	8000 A	160 - 250	24	95	35	270	215	240	180	20	34,00	
20055	20057	17411	10000 A	160 - 250	32	95	35	330	275	240	180	20	43,20	
20066	20068	17421	12000 A	160 - 250	40	95	35	390	340	240	180	20	51,10	
20077	20079	17431	14000 A	160 - 250	48	95	35	470	410	240	180	20	59,70	

Accessories/spare parts

30702 1 piece mounted insertion guide

17198 2-fold replacement foils

17199 3-fold replacement foils

30690 Replacement springs – stainless steel, standard version

30691 Replacement springs – stainless steel, heavy version

Note: All dimensions in the table are without installed protective covers. The versions with fitted protective covers include protective covers in standard design acc. to the following table. Ready to install versions with substructure on request.

All contact saddles are manufactured according to the modular principle so that individual foils as well as complete contact elements (contact fingers, foils and screw on material) can be replaced. For lighter product carriers (weight less than 50 kg) please contact us again, because the contact saddles must be set up accordingly.

Protective covers

Material: stainless steel A4,

suitable for contact saddles 4000 - 14000 A

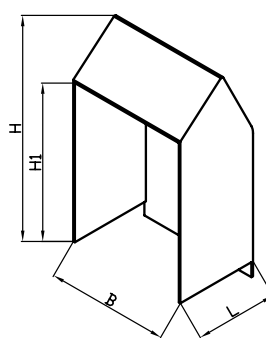

Standard design

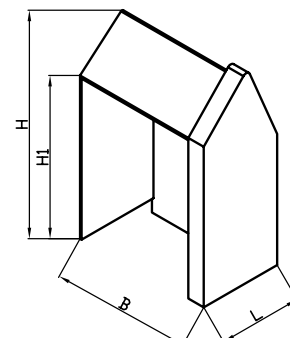

Heavy duty design

Part-No.		Technical data						
Protective covers standard design	Protective covers heavy duty design	suitable for contact saddle load	Part-No.	dimensions mm				
17301	17301 vst	4000 A	20011	L	B	H	H ₁	
17311	17311 vst	6000 A	20022	95	135	255	205	
17321	17321 vst	7000 A	20033	95	150	255	205	
17331	17331 vst	8000 A	20044	95	180	255	205	
17341	17341 vst	10000 A	20055	95	220	255	205	
17351	17351 vst	12000 A	20066	95	280	255	205	
17361	17361 vst	14000 A	20077	95	345	255	205	
				95	395	255	205	

Note: Protective covers in heavy duty design are equipped with an additional 10 mm thick stainless steel guide and are recommended especially for heavier product carriers.

The height of this design is ca. 20 mm and the width ca. 8 mm more than the dimensions of the standard designs described in the table.

High current finger contact saddles 250 - 4000 A

One-piece design with integrated insertion guides

Further developed contact series with insertion guides directly integrated into the basic model on both sides. Relatively small installation dimensions and easily exchangeable foil packages offer advantages compared with the older models on catalogue pages 8 and 9. The contact saddles are supplied in a one-piece version for product carrier thickness up to 20 mm and in a two-piece design for thicker product carriers.

On request also available as a ready-to mount-contact unit, i.e. mounted on an E-copper plate or angle with or without insulating plate, dimensionally matched to the installation situation. The design with stainless steel A4 protective covers protect the contact saddles against acid and alkali splashes. The contact saddles are manufactured according to the modular principle so that spare parts can be replaced without any problems.



Finger contact saddles in standard design

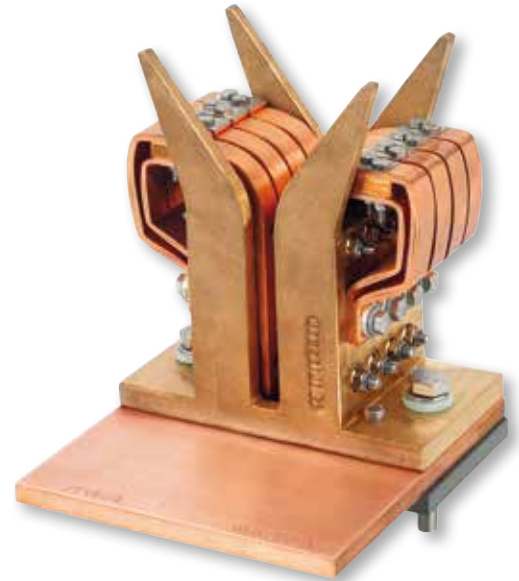

Finger contact saddle ready for installation with substructure



Finger contact saddle with protective covers

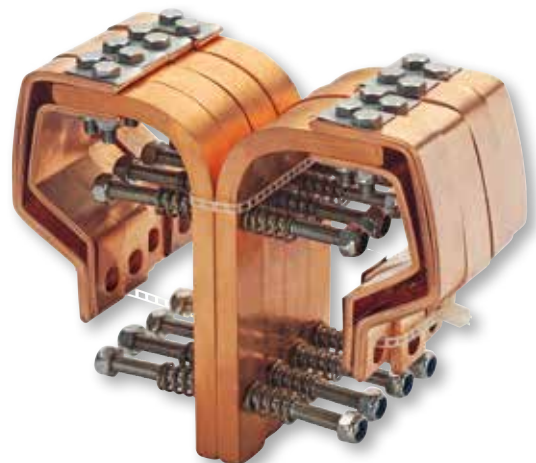

Ready to install replacement contact elements

Please also note our cleaning systems adapted to the contacts according to the catalogue pages 43-48.

High current finger contact saddles 250 - 4000 A

One-piece design
with integrated insertion guides

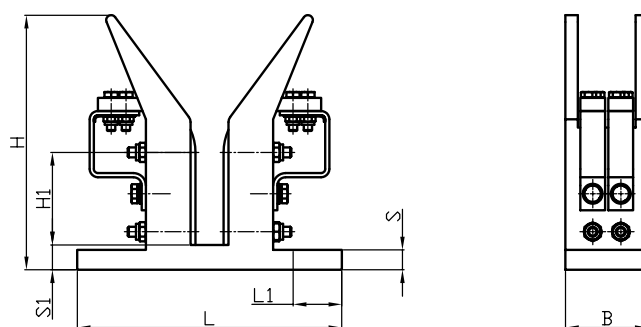
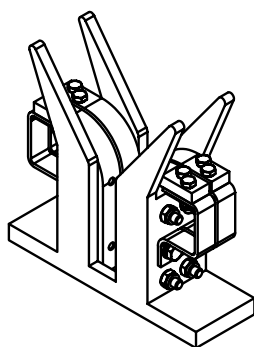

Part-No.			Technical data											weight kg/pcs without protective covers
contact saddle without stainless steel protective covers	contact saddle with stainless steel protective covers	1 set prefabricated replacement contact elements	max. current load	suitable for product carrier height mm	No. of contact fingers	dimensions mm								
						L	L ₁	B	H	H ₁	S	S ₁		
21005	21007	21305	250 A	40 - 60	2	160	35	50	150	60	12	15	3,10	
21010	21012	21310	500 A	40 - 60	4	160	35	50	150	60	12	15	3,60	
21015	21017	21315	500 A	80 - 120	4	160	35	50	180	85	12	15	4,20	
21020	21022	21320	750 A	40 - 60	6	160	35	70	150	60	12	15	4,40	
21025	21027	21325	750 A	80 - 120	6	160	35	70	180	85	12	15	5,00	
21030	21032	21330	1000 A	40 - 60	6	160	35	70	150	60	12	15	4,50	
21035	21037	21335	1000 A	80 - 120	6	160	35	70	180	85	12	15	5,10	
21040	21042	21340	1500 A	40 - 60	6	160	35	70	150	60	12	15	4,60	
21045	21047	21345	1500 A	80 - 120	6	160	35	70	180	85	12	15	5,20	
21050	21052	21350	2000 A	80 - 120	8	160	35	85	180	85	12	15	7,10	
21055	21057	21355	2500 A	80 - 120	10	190	45	100	180	85	15	20	9,40	
21060	21062	21360	2500 A	80 - 120	10	210	45	140	180	85	15	20	11,70	
21065	21067	21365	2500 A	100 - 160	10	210	45	140	205	105	15	20	13,20	
21070	21072	21370	3000 A	80 - 120	12	210	45	140	180	85	15	20	12,70	
21075	21077	21375	3000 A	100 - 160	12	210	45	140	205	105	15	20	13,80	
21080	21082	21380	3500 A	80 - 120	12	210	45	140	180	85	15	20	14,10	
21085	21087	21385	3500 A	100 - 160	12	210	45	140	205	105	15	20	15,40	
21090	21092	21390	4000 A	80 - 120	14	210	45	140	180	85	15	20	14,70	
21095	21097	21395	4000 A	100 - 160	14	210	45	140	205	105	15	20	16,20	

Springs as spare parts

30690 stainless steel springs, standard

30691 stainless steel springs, heavy version

Note: All dimensions in the table are without installed protective covers. The versions without fitted protective covers include protective covers in standard design acc. to the following table. Ready to install versions with substructure on request. All contact saddles are manufactured according to the modular principle so that all spare parts can be replaced without problem. Contact saddles for a product carrier-thickness of up to 20 mm are factory set as a one-piece model. For thicker product carriers the contact can be supplied separately in 2 halves.

When ordering please indicate the thickness and height of the product carrier. The product carrier thickness is also required when ordering replacement contact elements, as the lengths of the grub screws to be installed depend on it. For lighter product carriers (weight less than 50 kg) please contact us again, because the contact saddles must be set up accordingly.

Protective covers

Material: stainless steel A4,

suitable for contact saddles 250 - 4000 A

Part-No.	Technical data					
Protective covers standard design	suitable for contact saddle load	Part-No.	L	B	H	H ₁
21205	250 - 500 A	21005/10	75	54	155	90
21215	500 A	21015	75	54	185	120
21220	750 - 1500 A	21020/30/40	75	74	155	90
21225	750 - 1500 A	21025/35/45	75	74	185	120
21250	2000 A	21050	75	89	185	120
21255	2500 A	21055	95	104	185	120
21260	2500 - 4000 A	21060/70/80/90	105	139	185	120
21265	2500 - 4000 A	21065/75/85/95	105	139	210	145

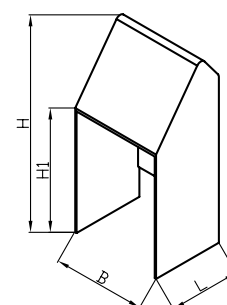

Note: When ordering protective covers for existing contact thickness or the delivery data of the contacts as the fixing saddles at a later data, please also state the product carrier holes on the covers must be positioned accordingly.

High current finger contact saddles 500 - 5000 A

for clamping of product carriers of different thickness without the need to change the setting

These contact saddles make contact with product carriers of different thickness (difference 10-15 mm depending on the model) in the same contact without the need to change the setting. This ensures safe operation both in the event of product carrier wear and when using product carriers of different thickness. For protection against acid and alkali splashes, we recommend the design with stainless steel A4 protective covers. Universally applicable contacts in compact design. Cost savings were achieved through standardization and reduction to a smaller number of sizes and components.

The contacts are delivered mounted on an E-Copper plate and adjusted to the thickness range of the product carriers. On request, mounting on an angle and delivery with an additionally mounted insulation plate is also possible. For applications where a current feed via a base plate or angle is not possible or disadvantageous, the current can also be fed via a bracket as shown in the photo. Detailed informations are available on request.

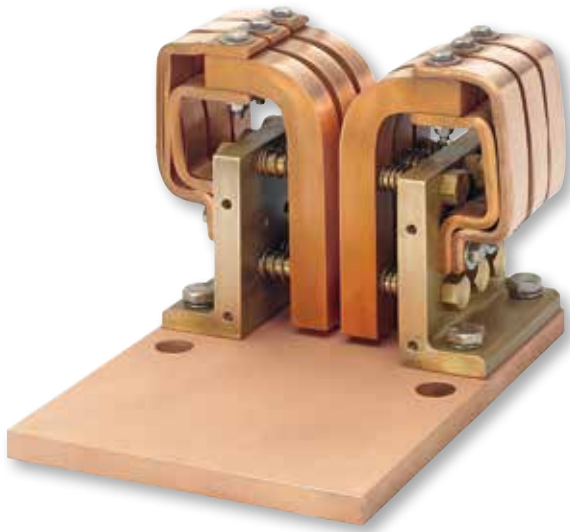

Standard contact saddle

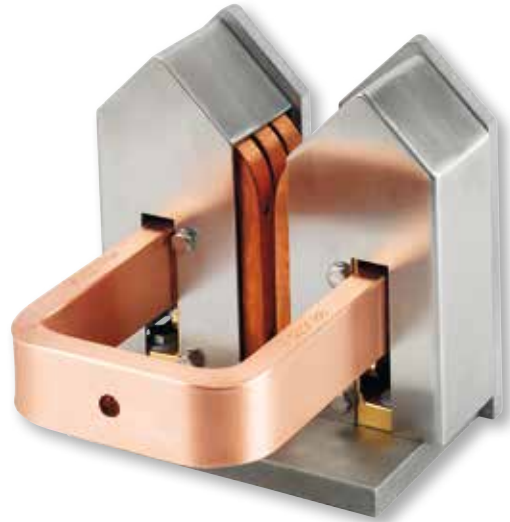

Contact saddle in special design with current feed through a bracket

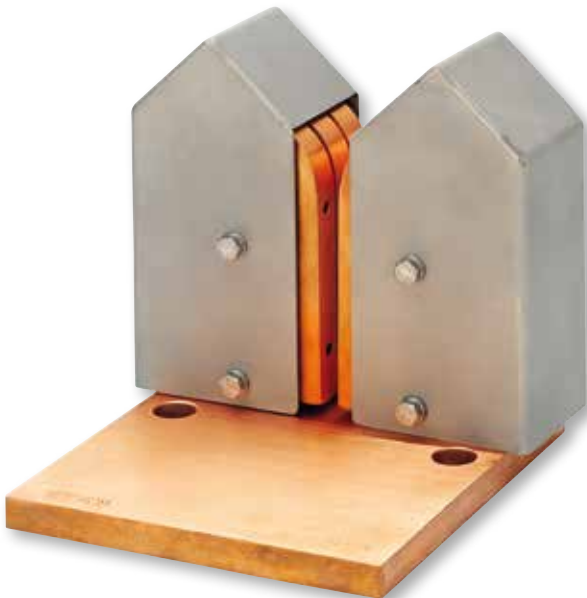

Contact saddle with protective cover



Replacement contact elements

Please also note our cleaning systems matched to our contacts according to the catalogue pages 43-48.

High current finger contact saddles 500 - 5000 A

for clamping of product carriers of different thickness without the need to change the setting

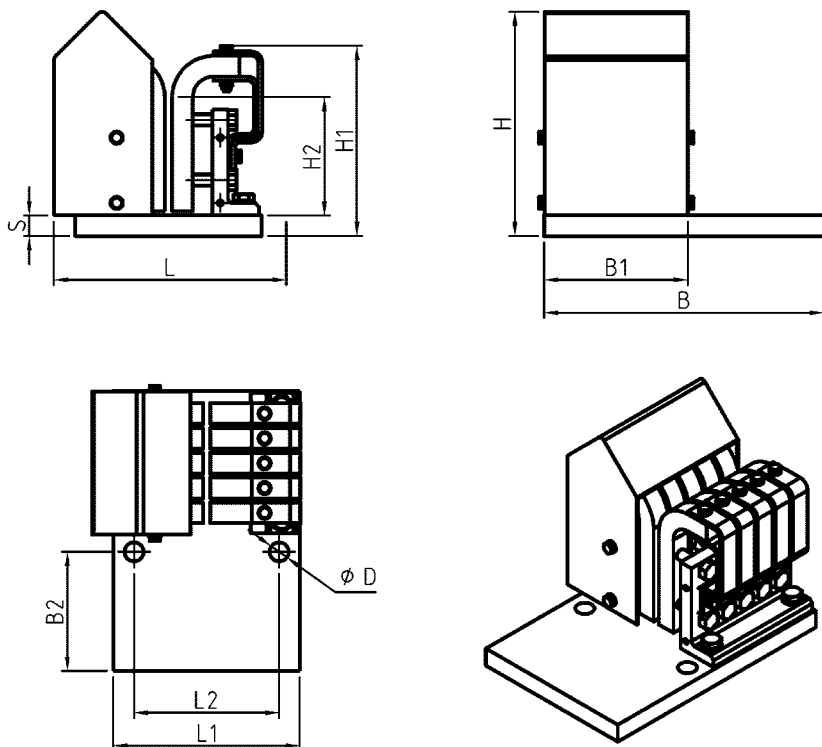

Standard design without protective covers

Part-No.		Technical data														Part-No.
Contact mounted on an E-copper plate	1 Set prefabricated replacement contact elements	max. current load	suitable for product carrier thickness x height		dimensions mm											insulated grommets as accessories
					L	L ₁	L ₂	B	B ₁	B ₂	H	H ₁	H ₂	S	D	
17009	17022	500 A	10 - 20	50 - 80	-	160	121	125	38	72	-	130	80	15	16,5	53455
17010	17023	500 A	10 - 20	60 - 120	-	160	121	125	38	72	-	150	97	15	16,5	53455
17011	17024	1500 A	10 - 20	60 - 120	-	160	125	170	55	100	-	160	101	15	16,5	53455
17012	17025	2000 A	10 - 25	60 - 120	-	165	129	180	55	110	-	160	101	15	16,5	53455
17013	17026	3500 A	10 - 25	80 - 160	-	180	140	240	100	120	-	180	114	15	18,5	53460
17014	17027	5000 A	10 - 25	80 - 160	-	180	140	270	135	115	-	185	114	20	18,5	53460

Standard design with mounted stainless steel A4 protective covers

Part-No.		Technical data														Part-No.
Contact mounted on an E-copper plate	1 Set prefabricated replacement contact elements	max. current load	suitable for product carrier thickness x height		dimensions mm											insulated grommets as accessories
					L	L ₁	L ₂	B	B ₁	B ₂	H	H ₁	H ₂	S	D	
17016	17022	500 A	10 - 20	50 - 80	170	160	121	125	41	72	158	-	80	15	16,5	53455
17017	17023	500 A	10 - 20	60 - 120	170	160	121	125	41	72	182	-	97	15	16,5	53455
17018	17024	1500 A	10 - 20	60 - 120	182	160	125	170	58	100	183	-	101	15	16,5	53455
17019	17025	2000 A	10 - 25	60 - 120	185	165	129	180	58	110	185	-	101	15	16,5	53455
17020	17026	3500 A	10 - 25	80 - 160	241	180	140	240	103	120	221	-	114	15	18,5	53460
17021	17027	5000 A	10 - 25	80 - 160	241	180	140	270	138	115	226	-	114	20	18,5	53460

Note: The specified product carrier thickness range in the table apply to a contact finger spacing of approx. 7 mm set in factory as standard = basic adjustment. If, in deviation from this basic setting, contact saddles are required for product carriers with other thickness ranges, please specify it in your order. The contact saddles then adjusted by us to the desired deviating thickness range. For lower product carrier heights than indicated in the table, the contacts can be supplied with an additionally mounted filler piece as height compensation.

For lighter product carriers (weight less than 50 kg) please contact us again, because the contact saddles must be set up accordingly. The insulating grommets made out of epoxy glass hard resin offered as accessories serve an insulation for the fixing screws and should be ordered as accessories for installations on metal tanks. For systems with bath movements, please contact us. The contact saddles must then be equipped with an additional limiter.

High current pneumatically actuated finger contact saddles 500 - 5000 A

for clamping of product carriers of different thickness without the need to change the contact setting

High current pneumatically actuated finger contact saddles for clamping of product carriers of different thickness without the need to change the contact setting (dimension difference in thickness max. 10 mm). This ensure safe operation both in the event of product carrier wear and when product carriers of different thickness are used. Therefore this contact series is equipped with a pneumatically actuated clamping force support. Each individual contact finger is actuated and pressed separately against the product carrier. The contact pressure required for contacting is generated by two small stainless steel pistons per contact finger. Available both with and without mounted stainless steel A4 protective covers.

Protective covers protect the contact saddles from acid and alkali splashes and thus extend the service life of the contact units. The standard designs are delivered mounted on an E-copper plate and adjusted to the product carrier dimension. On request, mounting on an angle and the delivery of an additionally mounted insulating plate is also possible. For applications where power feed via a base plate or angle is not possible or disadvantageous, the power can also fed in via straight or angled power connection bars leading out to the front, as shown in the following photo. Detailed informations are available on request.

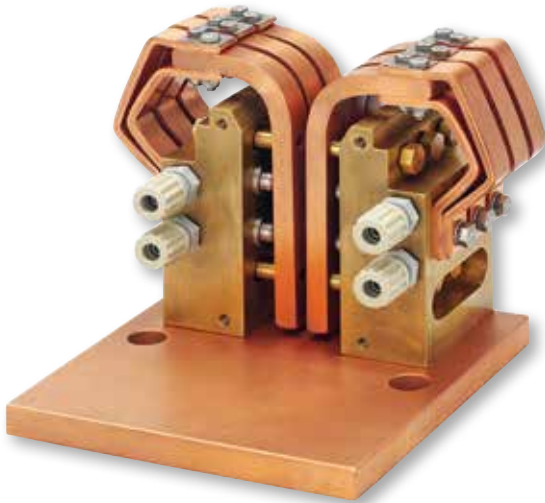

Standard finger contact saddle

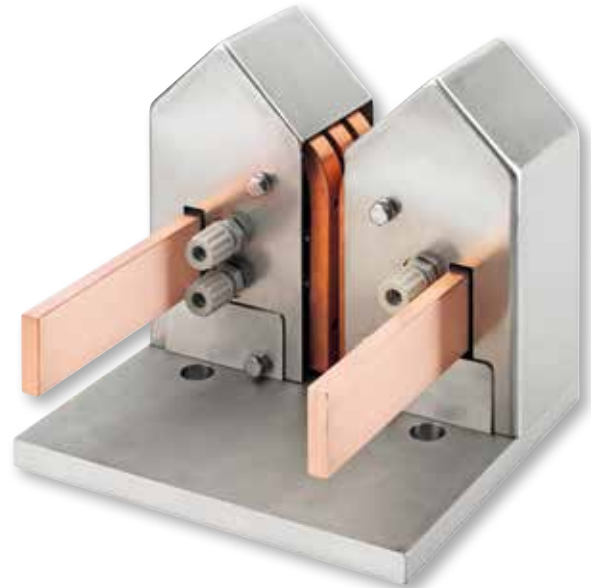

Special design with straight or angled power feed extending out to the front

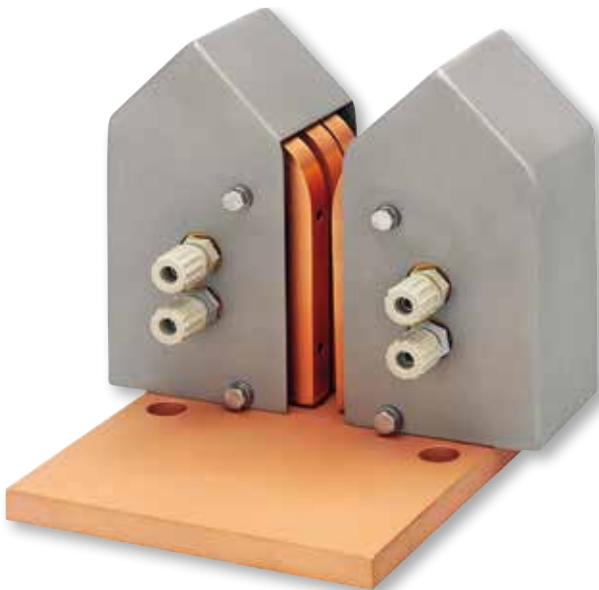

Contact saddle with mounted protective covers

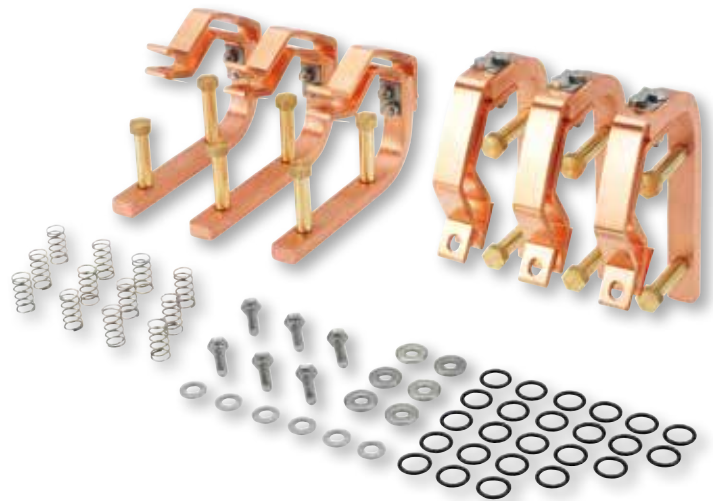

Replacement contact elements

Please also note our cleaning systems matched to our contacts according to the catalogue pages 43-48.

High current pneumatically actuated finger contact saddles 500 - 5000 A

for clamping of product carriers of different thickness without the need to change the contact setting

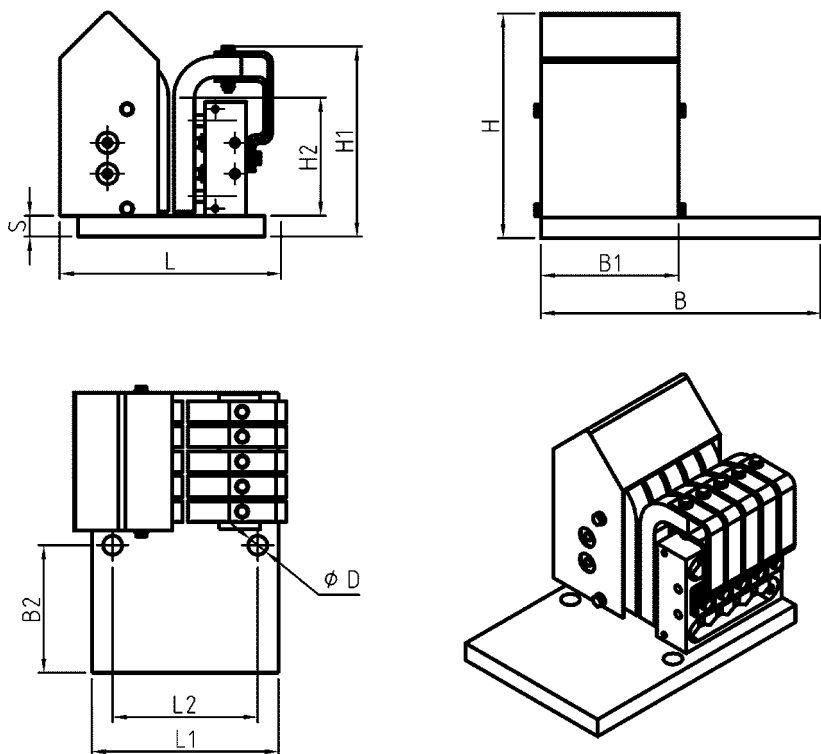

Standard design without protective covers

Part-No.		Technical data														Part-No.
Contact mounted on an E-copper plate	1 Set prefabricated replacement contact elements	max. current load	suitable for product carrier thickness x height		dimensions mm											insulated grommets as accessories
					L	L ₁	L ₂	B	B ₁	B ₂	H	H ₁	H ₂	S	D	
25000	25005	500 A	10 - 20	60 - 120	-	160	121	125	50	59	-	150	97	15	16,5	53455
25001	25006	1500 A	10 - 20	60 - 120	-	160	125	170	70	84	-	158	101	15	16,5	53455
25002	25007	2000 A	10 - 20	60 - 120	-	165	129	180	70	94	-	160	101	15	16,5	53455
25003	25008	3500 A	10 - 20	80 - 160	-	180	140	190	80	93	-	180	114	15	18,5	53460
25004	25009	5000 A	10 - 20	80 - 160	-	180	140	270	130	123	-	185	114	20	18,5	53460

Standard design with mounted stainless steel A4 protective covers

Part-No.		Technical data														Part-No.
Contact mounted on an E-copper plate	1 Set prefabricated replacement contact elements	max. current load	suitable for product carrier thickness x height		dimensions in mm											insulated grommets as accessories
					L	L ₁	L ₂	B	B ₁	B ₂	H	H ₁	H ₂	S	D	
25010	25005	500 A	10 - 20	60 - 120	198	160	121	125	54	59	190	-	97	15	16,5	53455
25011	25006	1500 A	10 - 20	60 - 120	198	160	125	170	74	84	190	-	101	15	16,5	53455
25012	25007	2000 A	10 - 20	60 - 120	206	165	129	180	74	94	190	-	101	15	16,5	53455
25013	25008	3500 A	10 - 20	80 - 160	236	180	140	190	84	93	225	-	114	15	18,5	53460
25014	25009	5000 A	10 - 20	80 - 160	236	180	140	270	135	123	230	-	114	20	18,5	53460

Note: The specified product carrier thickness range in the table apply to a contact finger spacing of approx. 7 mm set in factory as standard = basic adjustment. If, in deviation from this basic setting, contact saddles are required for product carriers with other thickness ranges, please specify it in your order. The contact saddles then adjusted by us to the desired deviating thickness range. For lower product carrier heights than indicated in the table, the contacts can be supplied with an additionally mounted filler piece as height compensation.

For lighter product carriers (weight less than 50 kg) please contact us again, because the contact saddles must be set up accordingly. The insulating grommets made out of epoxy glass hard resin offered as accessories serve an insulation for the fixing screws and should be ordered as accessories for installations on metal tanks. For systems with bath movements, please contact us. The contact saddles must then be equipped with an additional limiter.

Finger contact saddles 250 - 500 A for test and laboratory facilities



Contact saddles for smaller systems e.g. in the test and laboratory area. The current is transmitted via spring-mounted contact fingers that are connected to the base model by means of flexible insulated current connectors. The contact surfaces are cleaned as far as possible by abrasion when the product carrier slide in. The standard contact saddles are designed for a product carrier thickness of 10 mm.

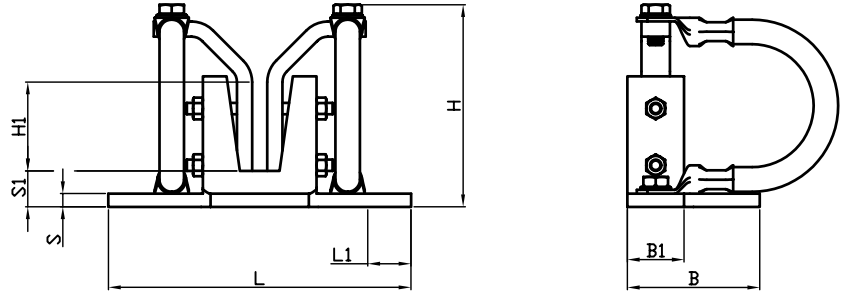

Part-No.	Technical data											
	max. current load	suitable for product carrier height mm	No. of contact fingers	dimensions mm								
L				L ₁	B	B ₁	H	H ₁	S	S ₁		
50230	250 A	50 - 80	2	160	25	70	30	110	45	7	20	1,0
50232	500 A	50 - 80	4	160	40	75	45	110	50	12	20	2,2

Spare parts

30690	Replacement springs – stainless steel - standard
50233	Insulated flexible replacement current connectors for contact saddles 50230
50234	Insulated flexible replacement current connectors for contact saddles 50232

Finger contact modules 400 - 600 A



Due to their small dimensions finger contact modules are suitable for use in confined spaces. They can also be used for higher currents by combining several modules. The mounting distance between two opposite contact modules must less than the thickness of the product carriers. This achieves the clamping effect and also cleans the contact surfaces as far as possible by abrasion when the product carrier slides in. Detailed installation informations are available on request.

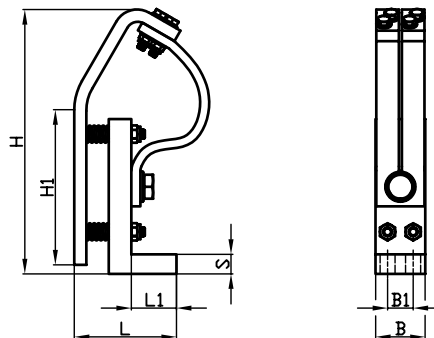

Part-No.	Technical data												
	design	max. current load	suitable for busbar height mm	dimensions mm									drilling-Ø
L				L ₁	B	B ₁	H	H ₁	S				
17000	2-fold	400 A	60 - 120	65	30	33	15	180	90	12	9	1,3	
17001	3-fold	600 A	60 - 120	65	30	50	30	180	90	12	9	1,9	

Spare parts

30690	Replacement springs – stainless steel – standard version
17198	2-fold replacement foils
17199	3-fold replacement foils

Bolt contact systems

Designs and current loads

We manufacture high current bolt contacts both as contact modules and as ready-to-mount contact units on a copper contact plate or angle in spring-loaded or pneumatically actuated design.

- Customized designs 800 - 12000 A
- Contact modules 400 - 1250 A
- Pneumatically actuated 800 - 6000 A

Advantages and design features

- **Current transfers:**
Via silver-plated spring-loaded E-Copper bolts by means of a beryllium lamella
- **Robust:**
Manufactured out of stable brass base bodies
- **Compact:**
Small installation dimensions even for contacts with high current rates
- **Repair-friendly:**
Only a small number of components. Easy replacement of the contact bolts without necessary disassembly of the contact unit.
- **Variable:**
Designs with as well as without pneumatic drive

We manufacture ready-to-use bolt contact systems for current loads up to 12000 A. Detailed informations are available on request. For a quotation we need the specification of the current load and the dimensions (height and thickness) of your product carriers.

High current bolt contacts 800 - 12000 A with spring-loaded contact bolts druseidt-system

druseidt high current bolt contacts consist of two identical contact halves which are adjusted to the required product carrier dimensions and are supplied mounted on an E-copper plate or angle. The current is transmitted via several point-shaped, spring-loaded E-copper contact bolts by means of a beryllium lamella.

The number and arrangement of the contact bolts depend on the desired current load and the height of the product carrier. The slide-in of the product carriers is caused by their own weight. In order to be able to guarantee this process, especially in fully automatic operation, it is recommended to chamfer the product carrier in the contact area.

The contact bolts can be replaced quickly from the outside and without the need to dismantle the contact unit from the tank. As standard, the contacts are supplied with silver-plated contact bolts Part-No. 50215. To improve current transmission, especially with longer bath times, and to reduce abrasion, contact bolts with soldered-on hard silver plate Part-No. 55215 are also available at extra costs. druseidt high current bolt contacts are a robust contact system with a stable, insensitive base body made of cast brass or solid brass material. Versions from 800 A-12000 A are available, which can be adapted to the requirements of your system.

druseidt high current bolt contacts offer a good alternative to any kind of simple solid cast contacts. They are relatively low-maintenance and only the ready-to-mount contact bolts including beryllium lamellae or only the individual beryllium lamellae are required as spare parts. Further informations are available on request.

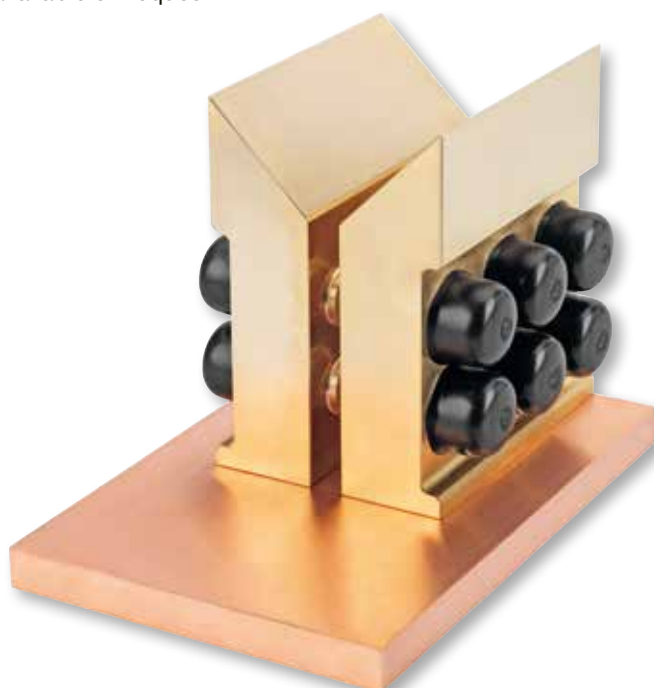

Bolt contact modules 400 - 1250 A

with spring loaded contact bolts

Bolt contact modules are suitable for installation in confined spaces or for applications without automatic operation. Among other things, they are also used for anode contacting. By combining several bolt contact modules, higher currents can also be transmitted. The current is transmitted via spring-loaded silver plated contact bolts Part-No. 50215 by means of a beryllium lamella.

The contact bolts are exchangeable from the outside without the need to dismantle the contact unit from the tank. On request, contact units mounted on an E-copper- or brass plate as well as equipped with contact bolts with soldered-on hard silver plate part-No. 55215 are also available.



Contact halves with 1/2 contact bolts



Contact halves with 3/4 contact bolts



Contact bolts part-No. 50215 and beryllium lamella part-No. 55219

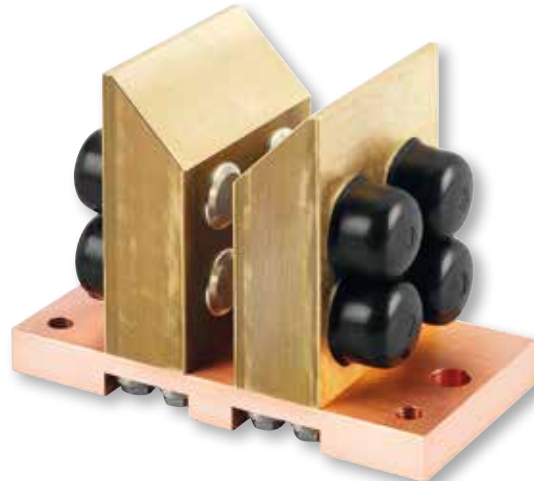

Bolt contact modules mounted on an E-copper plate

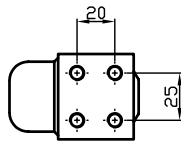
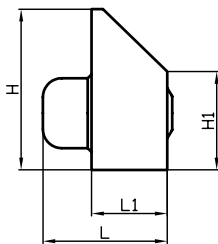
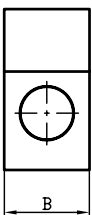

Mounting holes

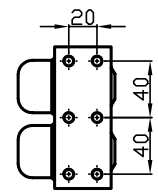
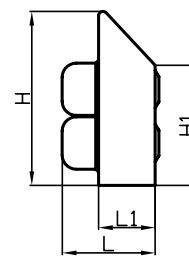
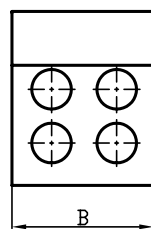

Mounting holes

Part-No.	Design	max. current load	Technical data						
			dimensions mm						
			L	L ₁	B	H	H ₁	drilling-Ø	weight kg/pcs.
17065	with 1 contact bolt	400 A	65	40	45	85	50	M8	1,20
17040	with 2 contact bolts	750 A	65	40	45	123	90	M8	1,70
17041	with 3 contact bolts	1000 A	65	40	100	123	90	M8	3,60
17042	with 4 contact bolts	1250 A	65	40	100	123	90	M8	3,70
Spare parts									
50215	Ready to install contact bolts, silver plated incl. beryllium lamella								
55215	Ready to install contact bolts with soldered-on hard silver plate incl. beryllium lamella								
55216	Stainless steel replacement springs, standard version								
55217	Stainless steel replacement springs, heavy version								
55219	Replacement beryllium lamella								

Pneumatically actuated high current bolt contacts and switching units

druseidt system with extremely high contact pressure

Today's requirements

In the course of the last decades, the plant and control technology of modern anodizing and electroplating plants has developed further and further. The cycle times, i.e. the time intervals in which product carriers enter the contacts and are under power, have become shorter and shorter in order to increase productivity, often even in 3-shift operation. As a result, the cooling down times in which the contacts are not energized have become shorter and shorter or almost non-existent. The contacts are thus under continuous current.

In addition, there are also processes that require extremely long power times, due to the process. Many older or simply designed systems are overtaxed by this as they were developed for different operating conditions, power cycles and cooling down times as today.

These increased requirements and technical advancements in plant engineering also require a further developed contact technology. We have taken this into account with the development of our pneumatically actuated bolt contact technology.

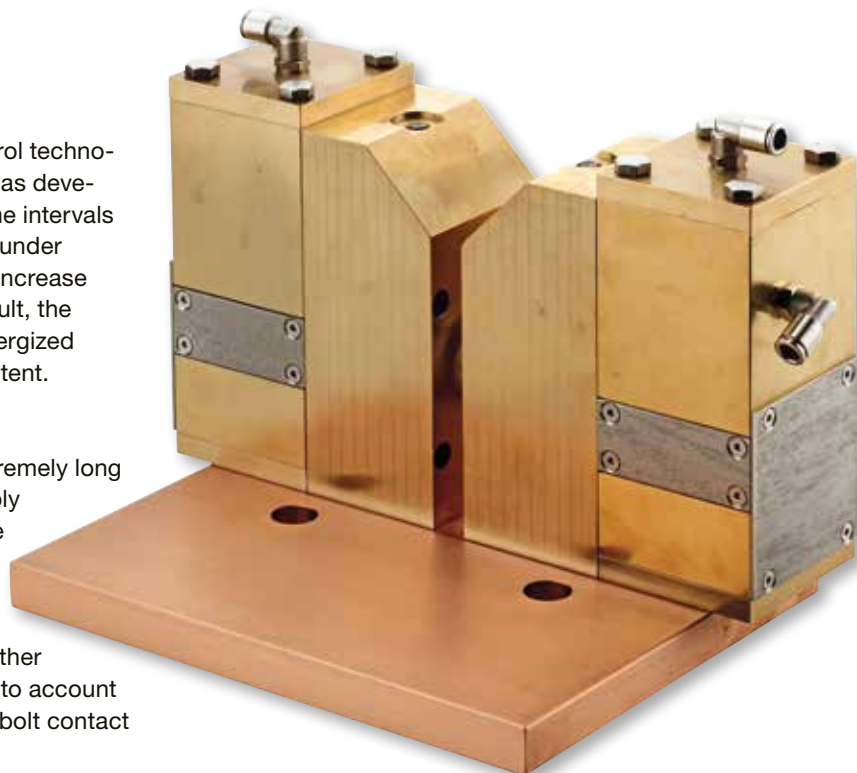

As contact unit for electroplating an anodizing plants.

or



As switching unit for various electrotechnical applications.

The further developed druseidt pneumatic bolt contact system

Based on today's requirements and the fact that the electrical contact resistance of a clamp or screw connection decreases up to a certain limit with increasing contact pressure, this new design of pneumatically actuated bolt contact system was developed. In addition to the sufficiently dimensioned conductor cross-sections, the incoming air pressure is converted to a very high surface pressure in this new druseidt pneumatic contact system by means of a mechanically well thought-out power transmission. Contact units up to 6000 A are offered as standard. However, since this contact system is manufactured in a modular design higher currents, e.g. 9000/12000 A, can also be realized by combining several contact modules. For applications where there is also a requirement that the contact pressure required for the current transmission, must be permanently maintained even in the event of failure or interruption of the compressed air supply, a series is also offered on catalogue pages 24-25 which ensures this.

Thus, in addition to the normal galvanotechnical applications, this system can also be used as load-free switching units for various other electrotechnical applications. All contacts are robust and are constructed in a low-maintenance design. Only the ready-to-mount contact bolts incl. seal and beryllium lamella which are available as spare parts, are required as wear or replacement parts.

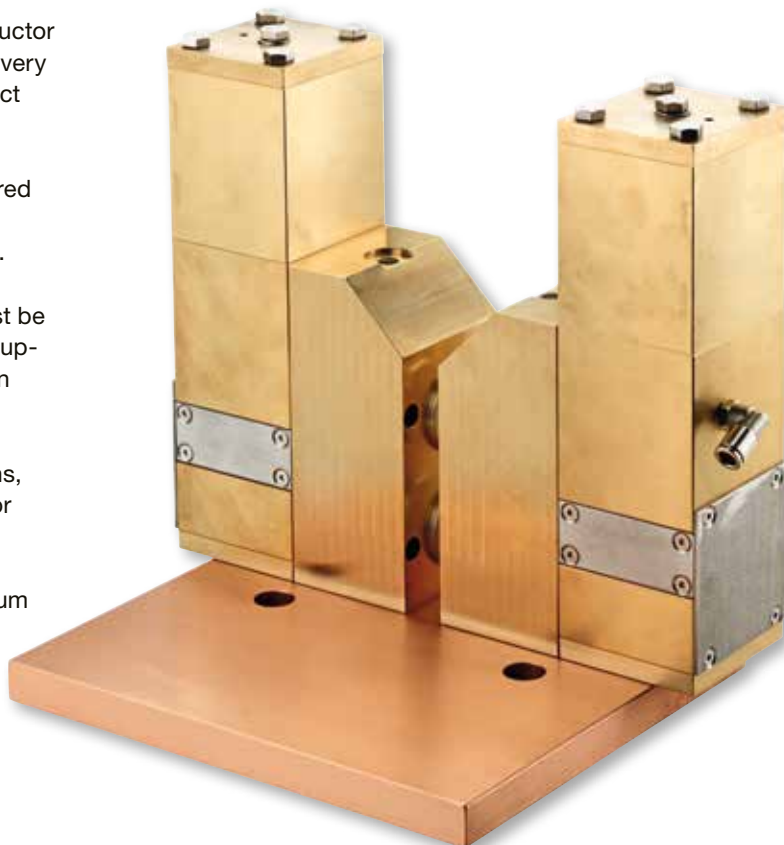

Pneumatically actuated bolt contacts 800 - 6000 A
preferably for use in electroplating and anodizing plants

Modular contact system in which the current is transmitted from the contact to the product carrier via silver plated copper bolts by means of beryllium contact lamellae. The contact resp. clamping of the product carrier is established by extending the contact bolts through inflowing compressed air. The contact is also reopened by applying compressed air via a second compressed air circuit. The contact bolts are housed in a sturdy brass base body and the two contact halves are supplied on a copper base plate (angle also available on request) as an assembled unit adjusted to the thickness and height of the existing product carriers.

With this newly developed pneumatic system the incoming air pressure in the series from 1500 A generates a very high surface pressure due to a mechanically well thought-out additional power transmission. It is thus considerably higher than with a normal pneumatic design with a simple piston/compressed air cylinder or pneumatic cushion. For the operation of the contacts we recommend the use of a 5/2 way valve. The contact bolts retract completely when this valve is used so that the product carriers can retract without contact.

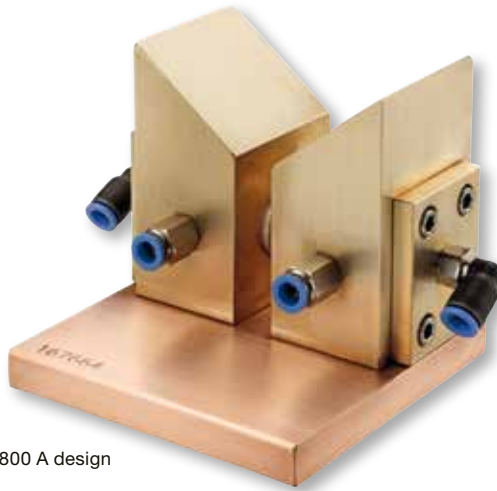

800 A design

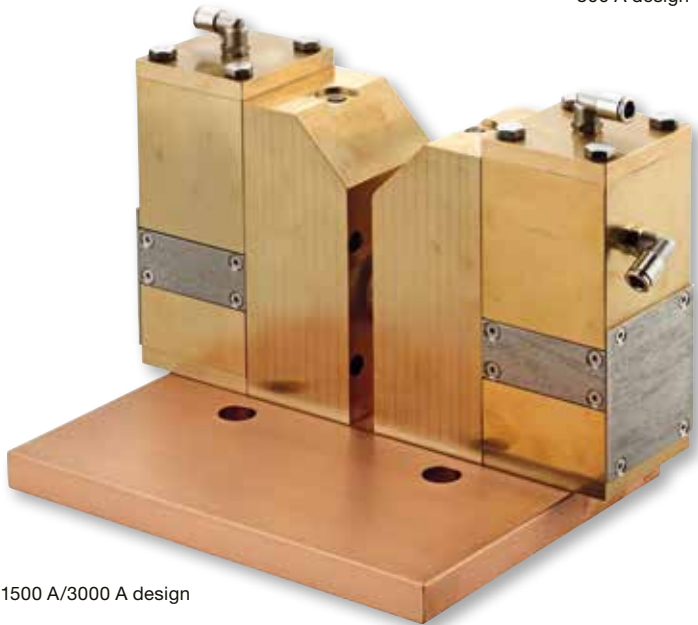

1500 A/3000 A design

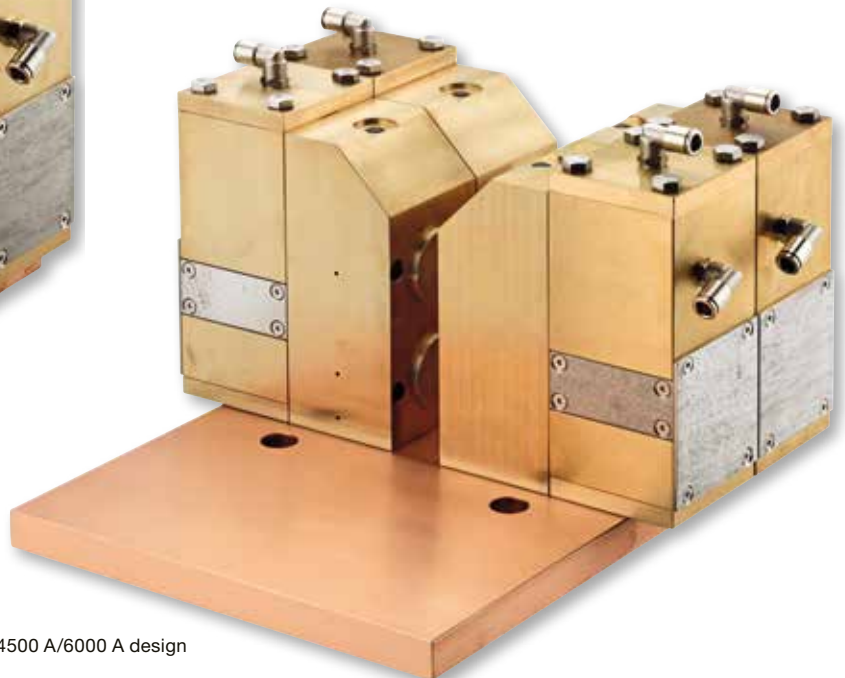

4500 A/6000 A design

Please also note our cleaning saddles matched to our pneumatically actuated bolt contacts acc. to the catalogue page 26.

Pneumatically actuated bolt contacts 800 - 6000 A

preferably for use in electroplating and anodizing plants

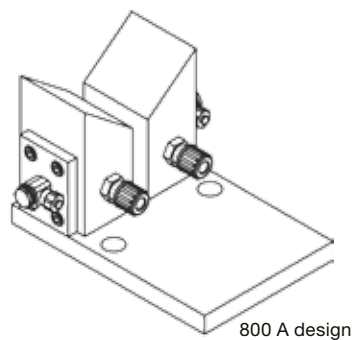
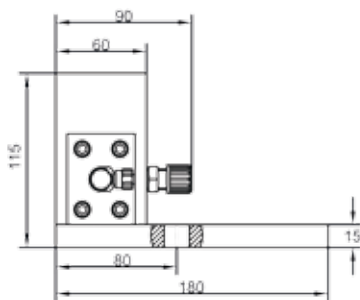
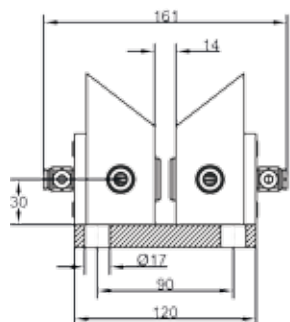

800 A design

Part-No.	Technical data		
	max. current load	No. of contact bolts	Description
17068	800 A design	2	Relatively small pneumatically actuated contact units for product carrier heights from 50 mm to approx. 80 mm. Can be used wherever, for example, automatic sliding into spring-mounted contacts with pretension is not possible due to the low weight of the product carriers. The base plate can be dimensionally modified or replaced by an angle on request. The drawn dimensions refer to a product carrier thickness of 10 mm.
17069	Replacement contact bolt, silver plated, ready for mounting incl. sealing rings and contact lamella		
55219	Replacement contact lamella		

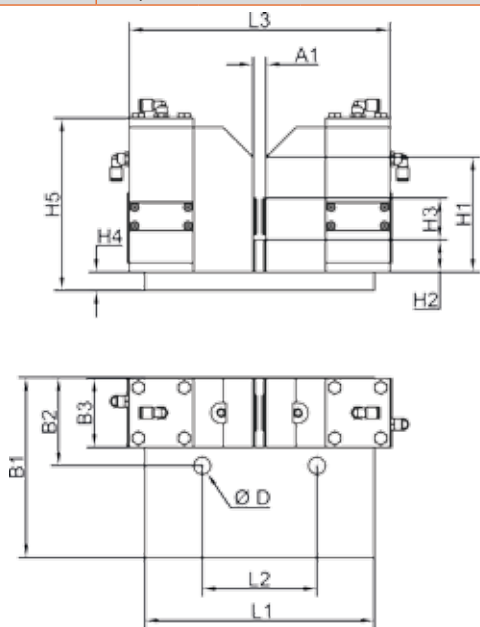

1500 A/3000 A design

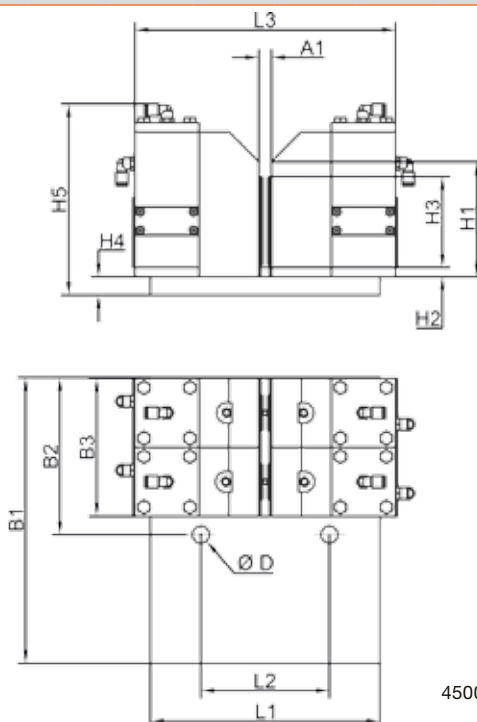

4500 A/6000 A design

Part-No.	Technical data															
	max. current load	for product carrier height	No. of contact bolts	dimensions mm												
				A ₁	B ₁	B ₂	B ₃	H ₁	H ₂	H ₃	H ₄	H ₅	L ₁	L ₂	L ₃	L ₄
25420	1500 A	50	2	14	196	96	75	125	35	45,5	20	208	250	125	284	18,5
25422		60							30	50,5						
25424		80							20	60,5						
25426		ab 100							-	80,5						
25428	3000 A	100	4	19	216	96	75	125	10	99	20	208	250	140	289	18,5
25430		ab 120							-	109						
25432	4500 A	100	6	24	311	171	150	125	10	99	20	208	250	140	294	18,5
25434		ab 120							-	109						
25436	6000 A	100	8	24	311	171	150	125	10	99	20	208	250	140	294	18,5
25438		ab 120							-	109						
25470	Replacement contact bolt, silver plated, ready for mounting incl. sealing rings and contact lamella															
25471	Replacement contact lamella															

Note: The dimensions given in the table are for contacts 1500 A for 10 mm, for contacts 3000 A for 15 mm and for contacts from 4500 A 20 mm thick product carriers. The base plates in the standard version can be used up to a product carrier thickness of 100 mm without changing the dimensions by moving the contact block halves.

In case of an order, please state therefore the height and thickness of your product carrier. If desired, the base plate can of course be changed or replaced by an angle. Due to the modular design contact units for higher currents e.g. 9000 A/12000 A etc. can also be assembled.

Pneumatically actuated bolt-contacts 1500 - 6000 A

preferably for use as load-free switching units

The design is similar to our pneumatically actuated bolt-contacts for use in electroplating and anodizing plants, but this new contact system takes into account the requirement that the air pressure required for power transmission must be maintained permanently even in the event of a failure or interruption of the compressed air supply. All these contacts are therefore equipped with an additional construction that reliably ensures this.

They can therefore be used as load-free switching elements for a wide variety of applications in control panels or other electrotechnical applications.

The function takes place like this:

Air in = contact opens and the busbar can retract.

Then depressurize and the contact clamps the busbar.

To extend the busbar, pressurize the contact with air again.

To realize this, we recommend using a 3/2 way valve to operate the contacts.



1500 A/3000 A design



4500 A/6000 A design

Pneumatically actuated bolt-contacts 1500 - 6000 A

preferably for use as load-free switching units

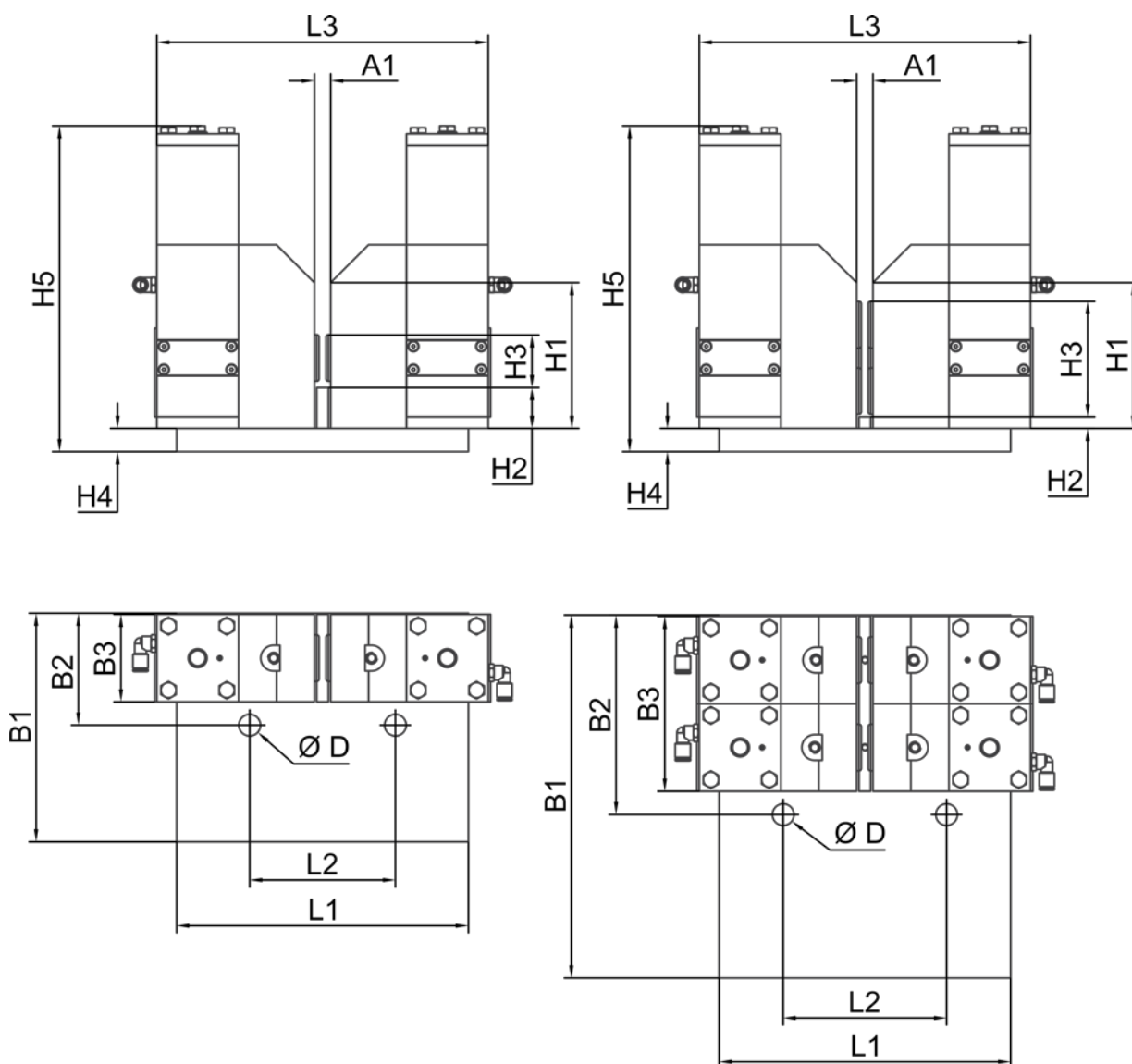

1500 A/3000 A design

4500 A/6000 A design

Part-No.	Technical data															
	max. current load	for busbar-height	No. of contact bolts	dimensions mm												
				A ₁	B ₁	B ₂	B ₃	H ₁	H ₂	H ₃	H ₄	H ₅	L ₁	L ₂	L ₃	L ₄
25440	1500 A	50	2	14	196	96	75	125	35	45,5	20	278	250	125	284	18,5
25442		60							30	50,5						
25444		80							20	60,5						
25446		ab 100							-	80,5						
25448	3000 A	100	4	19	216	96	75	125	10	99	20	278	250	140	289	18,5
25450		ab 120							-	109						
25452	4500 A	100	6	24	311	171	150	125	10	99	20	278	250	140	294	18,5
25454		ab 120							-	109						
25456	6000 A	100	8	24	311	171	150	125	10	99	20	278	250	140	294	18,5
25458		ab 120							-	109						
25470	Replacement contact bolt, silver plated, ready for mounting incl. sealing rings and contact lamella															
25471	Replacement contact lamella															

Note: The dimensions given in the table are for contacts 1500 A for 10 mm, for contacts 3000 A for 15 mm and for contacts from 4500 A 20 mm thick busbars. The base plates in the standard version can be used up to a busbar thickness of 100 mm without changing the dimensions by moving the contact block halves.

In case of an order, please state therefore the height and thickness of your product carrier. If desired, the base plate can of course be changed or replaced by an angle. Due to the modular design contact units for higher current e.g. 9000 /12000 A etc. can also be assembled.

Cleaning saddles for product carriers

Suitable for parallel use with pneumatically actuated bolt contacts
acc. to catalogue pages 22-25

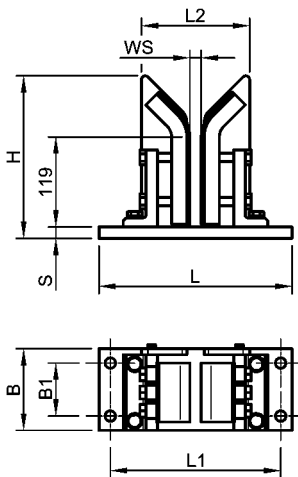
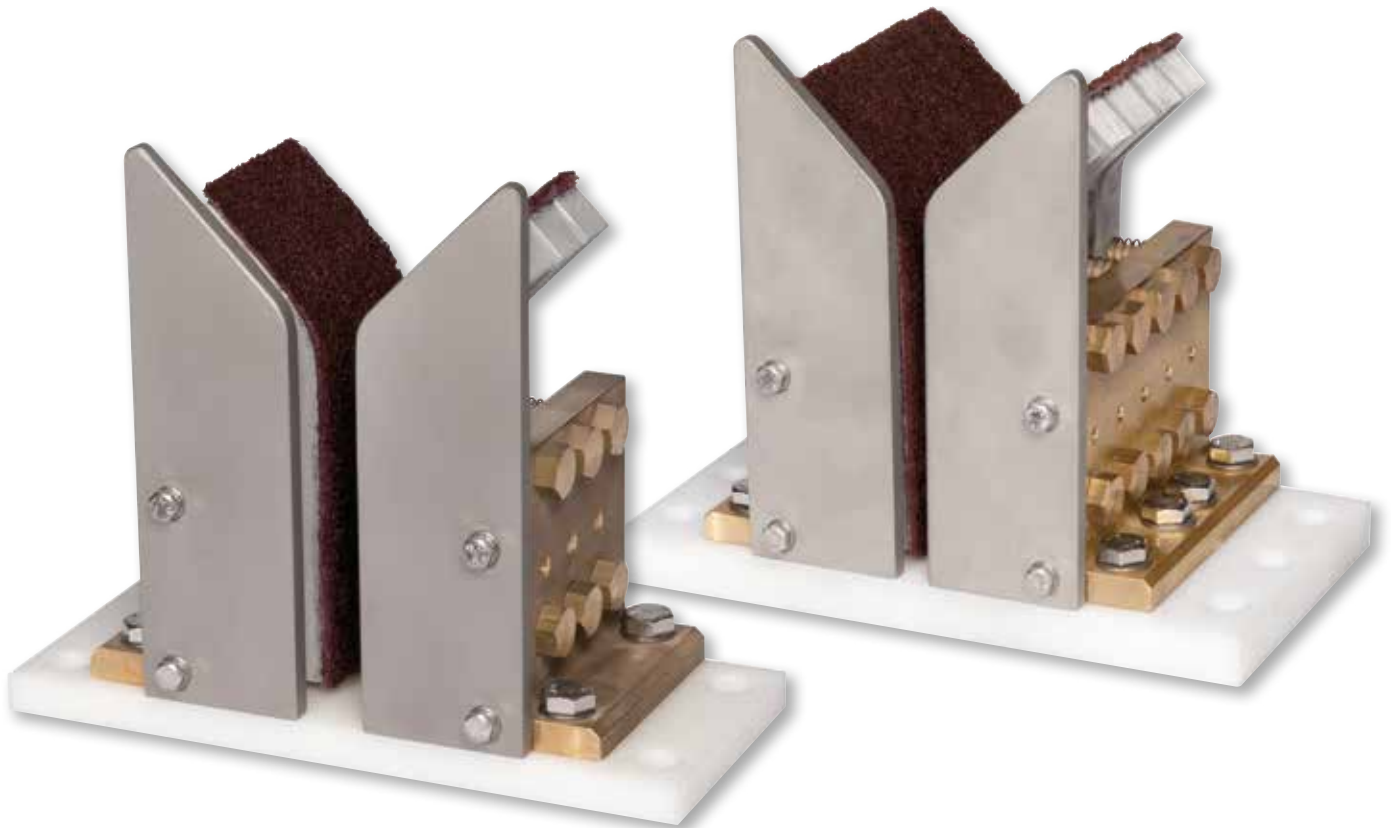

Part-No. 36005-20

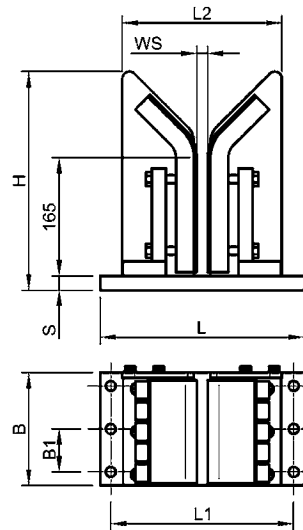

Part-No. 36054-20

Part-No.		Technical data								
Complete cleaning saddle	Complete replacement half	Suitable for bolt contact current load	dimensions mm							weight kg/pcs.
			L	L ₁	L ₂	B	B ₁	H	S	
36005-20	36005-A	800-3000 A	255	225	143	108	1 x 70	215	15	7
36054-20	36054-A	4500-6000 A	285	255	233	158	2 x 60	305	25	19

Note: The dimensions listed in the table are based on a product carrier thickness of 20 mm. For product carrier thicknesses that deviate from this the width dimensions change accordingly.

In case of an order, please state therefore the height and thickness of your product carrier.

In addition to the standard designs, we also manufacture designs acc. to your wishes e.g. for other contact surface lengths. You will find further standard designs here on the catalogue pages 45-48.

Hydro-pneumatically actuated contact systems

Hydro-pneumatically actuated contact systems druseidt-Titan with hydro pneumatic drive the innovative and unique high current contact system for anodizing and electroplating plants.

Based on the fact that the electrical contact resistance decreases with increasing the contact pressure, the Titan-System was developed.

Due to a completely new design of force amplification by means of a hydro pneumatic force drive, this druseidt contact series generate an extremely high constant contact pressure of up to several thousand Newtons per contact finger.



Please also note our cleaning systems matched to our contacts according to the catalogue pages 43-48.

High current contact saddles „druseidt-Titan” – a perfect system for perfect applications

Theoretical basis on the subject of electrical connection and contact resistance

The quality of an electrical connection depends on the material, cross-section and dimensions of the contact surfaces as well as on the contact pressure and the surface quality of the contact points. These criteria influence the electrical contact resistance and thus the quality and service life of the connection. The electrical contact resistance of a clamp or screw connection decreases up to a certain limit with increasing contact pressure.

The „Titan“ system

The contact pressure of conventional spring actuated contact saddles depends on the spring strength used and reaches values of approx. 200 N per contact finger. This pressure can be increased of over 1000 N for a complete contact saddle (e.g. for plate contacts) with conventional pneumatic drives. The aim of our development was therefore to increase the contact pressure so that a clamp connection can be made with the minimum contact pressure of a DIN-compliant screw connection. Depending on the size and air pressure, the druseidt Titan-system achieves a contact pressure of 50 kN to over 100 kN (see diagrams on pages 31 und 34). All contact saddles of the Titan series are equipped with further developed protective covers made of A4 stainless steel and are designed to be plug-in. This makes it possible to simply remove the protective covers without time-consuming disassembly work to carry out both inspection and cleaning activities quickly and easily.

The „Titan“ system

In addition to low contact forces, contamination on the contact surfaces in the area of electroplating and anodizing plants is a main cause of high connection and contact resistances. This results in power losses and strong heating at the contact points, which in the worst case can lead to total failure of the systems. Coating problems, expensive repairs and system downtimes are the result of this. In order to be able to make optimizations here as well, we also developed various cleaning saddles and cleaning devices in addition to our various kinds of high current contact saddles which, e.g. in combination with our Titan contact saddle series described below, can additionally contribute to process optimization. **Therefore, please also note our cleaning systems adapted to our contact saddles according to the catalogue pages 43-48.**

The hydro-pneumatic drive

The contact fingers of the Titan-system are individually pressed against the contact surfaces of the product carriers by means of a hydro-pneumatically force booster. This power booster, newly developed by us, converts the incoming air pressure via hydraulics into a very high contact pressure at the contact fingers. The hydraulics do not work with oil but with water. This reliably prevents the baths from becoming dirty in the event of leaks. A water refill unit integrated into the contact can also be used to refill the water quantity in the event of water loss. In order to ensure absolute tightness for a long period of time all sealing elements have been tested in long-term tests and designed for the specific requirements of galvanotechnology.

Product benefits that pay off:

- Significant reduction of electrical contact and connection resistance compared with conventional systems
- Significant reduction of power losses and optimization of the process flow
- Reduction of the necessary cleaning effort
- Reduction of system downtimes due to repairs
- Different standard series and production according to the modular principle allow individual adaptation to different designs of systems and installation situations
- All contact series from 6000 A with dimensional difference compensation for clamping product carriers of different thickness or not quite true to size
- Durable quality “Made in Germany”

Minimized electrical contact resistance
due to previously unattained contact pressure



- Standard for currents from 3000 up to 15000 A
- Series from 6000 A with dimensional difference compensation
- Special designs also available for currents > 15000 A
- Self-cleaning effect due to abrasion when the product carriers slide in



Overview of the available standard designs of contact saddles „druseidt-Titan“ of the series 3000-5000 A as well as 6000-15000 A

current load	Part.-No.		Part.-No.
3000 A	25050		25350
4000 A	25051		25351
5000 A	25052		25352
6000 A	-		-
8000 A	-		-
10000 A	-		-
12000 A	-		-
15000 A	-		-

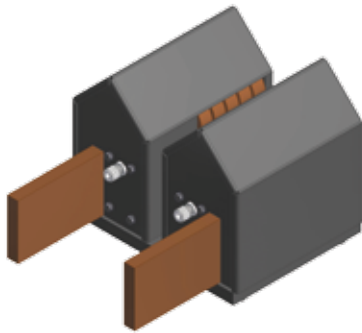

Type 1

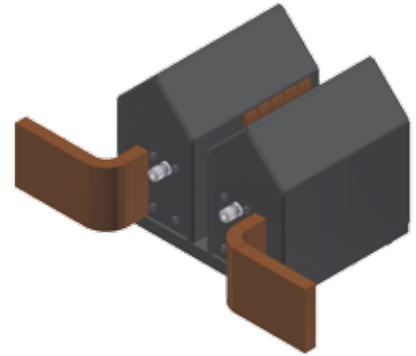

Type 2

current load	Part.-No.		Part.-No.
3000 A	25150		25250
4000 A	25151		25251
5000 A	25152		25252
6000 A	25153/25553		25253/25653
8000 A	25154/25554		25254/25654
10000 A	25155/25555		25255/25655
12000 A	25156/25556		25256/25656
15000 A	25157/25557		25257/25657

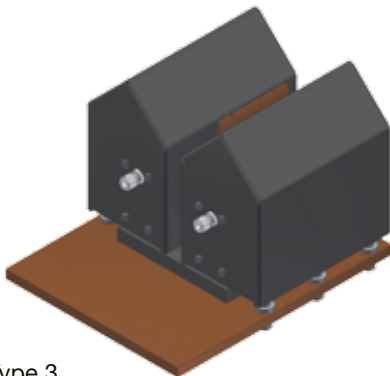

Type 3

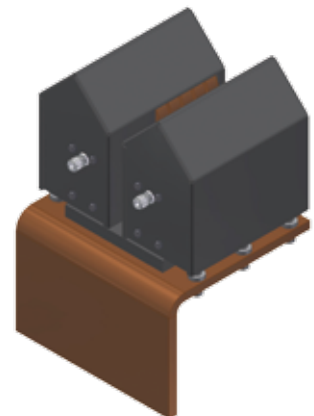

Type 4

Hydro-pneumatically actuated high current contact saddles „druseidt-Titan“ 3000 - 5000 A

System description

Equipped with a hydro-pneumatic power booster. Contact pressure per contact finger according to the following diagram. Hydraulic drive by means of water. All contact fingers are actuated individually so that they clamp securely and permanently against the surfaces of the product carrier. The contact fingers are supplied mounted with a preload. In this way, the contact surfaces are cleaned as far as possible by abrasion when the product carriers slide in. Standard with pluggable protective covers made of A4 stainless steel.

Optionally with or without temperature sensor PT100. Mounted on a stable stainless steel plate to absorb the very high compressive forces.

Available designs

In order to be able to connect to the respective busbar system, flexible connectors or cables are not absolutely necessary. All versions can be connected with rigid busbars. Connection options according to type 1-4 analogous to the drawings on page 30.

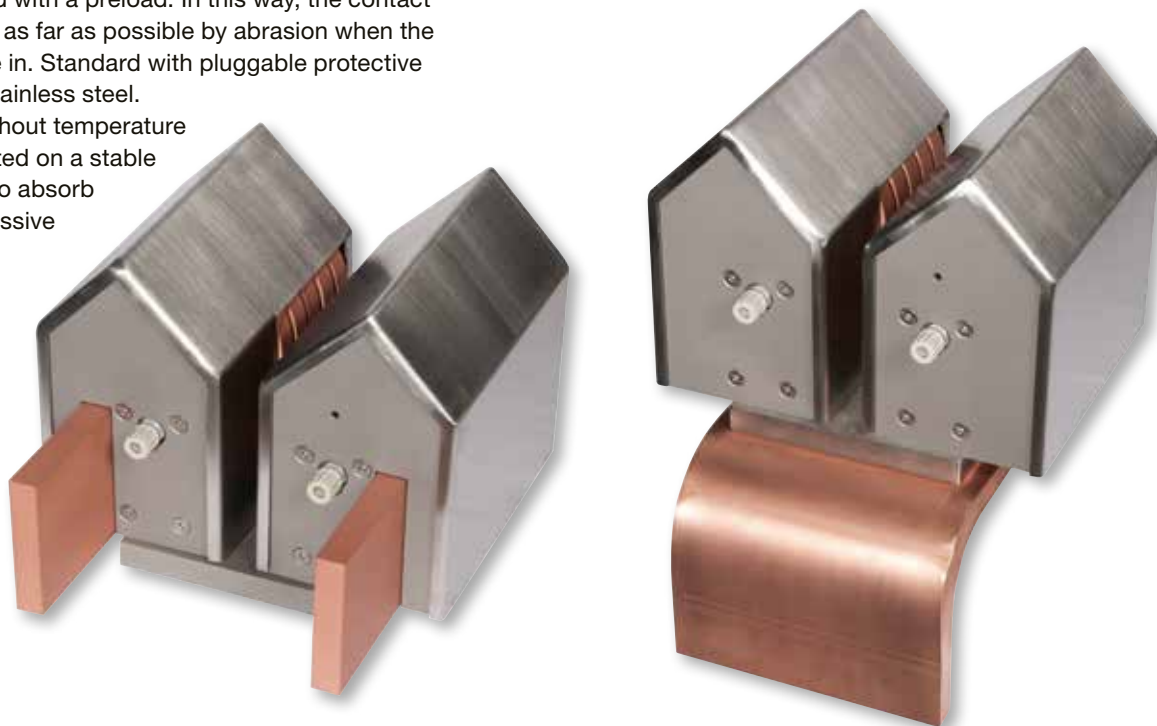

Clamping force development series 3000-5000 A acc. to catalogue pages 32-33

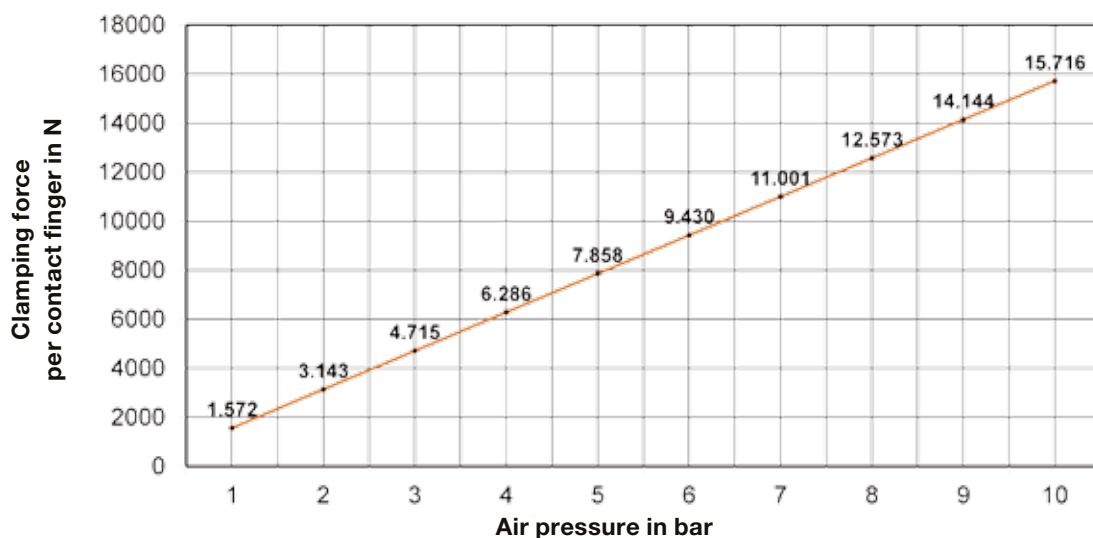

At an air pressure of 6 bar, the total contact pressure of one contact saddle reaches the following values:

Model 3000 A = ca. 56,5 kN

Model 4000 A = ca. 75,5 kN

Model 5000 A = ca. 94,3 kN

Hydro-pneumatically actuated high current contact saddles "druseidt-Titan" 3000-5000 A

Standard versions

with straight connection busbars leading out to the front

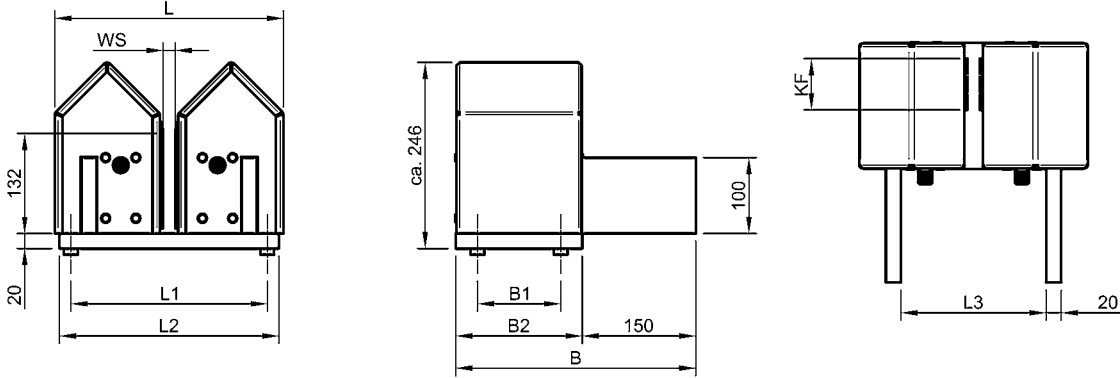

Part-No.	max. current load	Technical data								weight kg/pcs.
		dimensions mm								
		L	L ₁	L ₂	L ₃	B	B ₁	B ₂	KF	
25050	3000 A	304	260	290	194	317	110	167	68	48
25051	4000 A	304	260	290	194	359	150	209	92	58
25052	5000 A	304	260	290	194	383	180	233	116	65

Standard versions

with 90° angled connection busbars leading out to the front

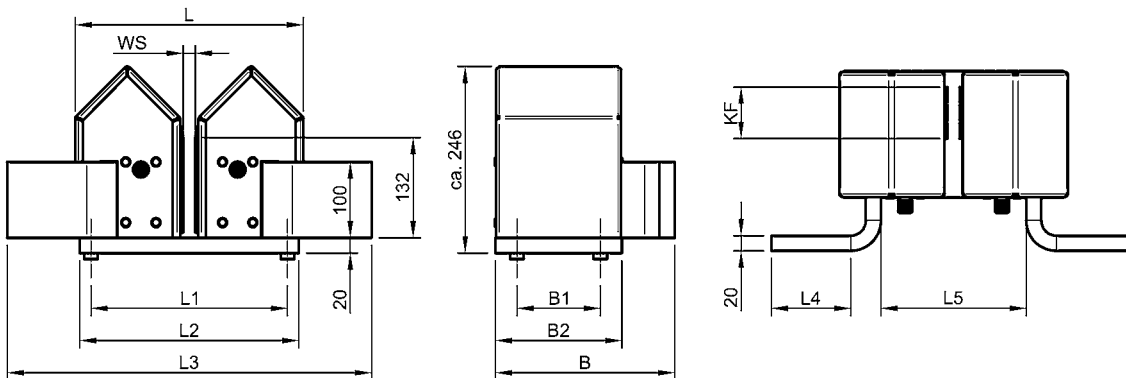

Part-No.	max. current load	Technical data										weight kg/pcs.
		dimensions mm										
		L	L ₁	L ₂	L ₃	L ₄	L ₅	B	B ₁	B ₂	KF	
25350	3000 A	304	260	290	482	105	194	237	110	167	68	49
25351	4000 A	304	260	290	482	105	194	279	150	209	92	59
25352	5000 A	304	260	290	522	125	194	303	180	233	116	67

Note: The dimensions shown in the tables are based on a product carrier thickness of 20 mm. If the thickness of the product carriers deviates from this, the width dimensions of the contact units change accordingly.

Minimum height of the product carriers 60/80 mm. For 60 mm or less than 80 mm high product carriers the contact units must be supplied with an additionally mounted copper filler piece as height compensation. On request, all contact saddles are also available with a PT100 temperature sensor.

Hydro-pneumatically actuated high current contact saddles "druseidt-Titan" 3000-5000 A

Standard version

mounted on an E-copper plate

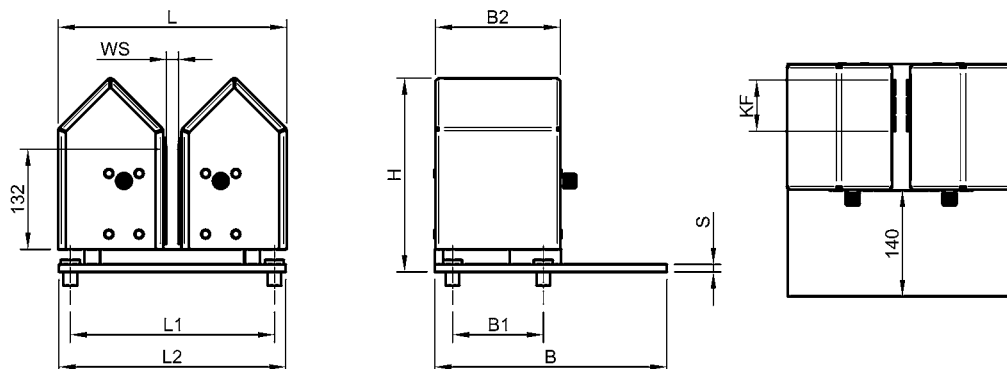

Part-No.	Technical data	dimensions mm									weight kg/pcs.
		max. current load	L	L ₁	L ₂	B	B ₁	B ₂	H	S	
25150	3000 A	304	270	300	307	120	165	256	10	68	46
25151	4000 A	304	270	300	349	2 x 80	207	258	12	92	58
25152	5000 A	304	270	300	373	2 x 90	231	261	15	116	68

Standard version

mounted on an E-copper angle

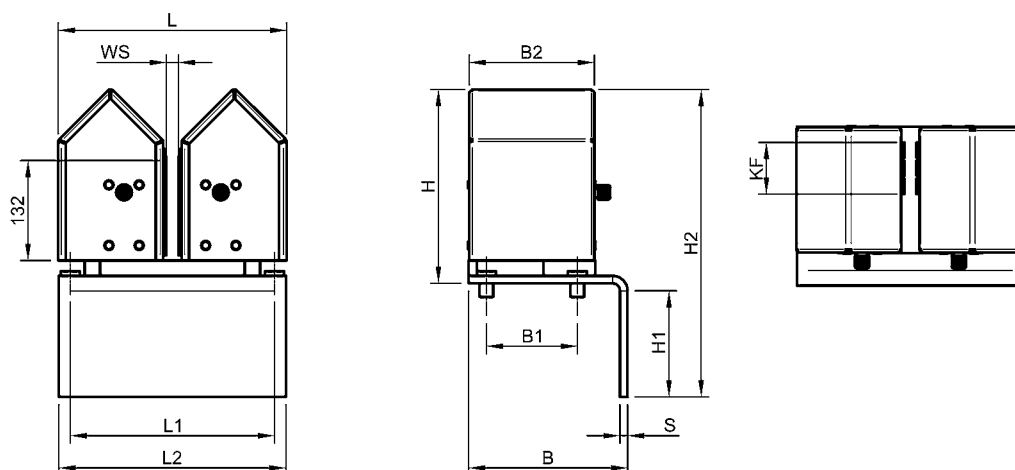

Part-No.	Technical data	dimensions mm											weight kg/pcs.
		max. current load	L	L ₁	L ₂	B	B ₁	B ₂	H	H ₁	H ₂	S	
25250	3000 A	304	270	300	210	120	165	256	140	406	10	68	47
25251	4000 A	304	270	300	250	2 x 80	207	258	136	406	12	92	59
25252	5000 A	304	270	300	275	2 x 90	231	261	170	446	15	116	71

Note: The dimensions shown in the tables are based on a product carrier thickness of 20 mm. If the thickness of the product carriers deviates from this, the width dimensions of the contact units change accordingly.

Minimum height of the product carriers 60/80 mm. For 60 mm or less than 80 mm high product carriers the contact units must be supplied with an additionally mounted copper filler piece as height compensation. On request, all contact saddles are also available with a PT100 temperature sensor.

Hydro-pneumatically actuated high current contact saddles

„druseidt-Titan“ 6000 - 15000 A

with measurement difference compensation

System description and available designs

Equipped with a hydro-pneumatic power booster. Contact pressure per contact finger according to the following diagram. Hydraulic drive by the means of water. All contact fingers are actuated individually so that they can clamp securely and permanently against the surfaces of the product carrier. The contact fingers are designed in such a way that a dimensional difference compensation of 10 mm takes place with hydro-pneumatic actuation on both sides. This means that product carriers of different thicknesses, e.g. in case of rail wear or rails that are warped in the contact area, can be operated safely without costly modification or conversion of the contacts. The contact fingers are supplied mounted with a preload.

In this way, the contact surfaces are cleaned as much as possible by abrasion when the product carriers slide in. Standard with pluggable protective covers made of A4 stainless steel. Optionally with or without temperature sensor PT 100. Mounted on a stable stainless steel plate to absorb the very high compressive forces. In order to be able to connect to the respective busbar system, flexible connectors or cables are not absolutely necessary. All contact versions can be connected with rigid busbars. In order to be able to adapt the contact saddles to the often very different space conditions available, a shorter but somewhat wider compact design is offered (page 36) in addition to the standard versions (page 35).



Clamping force development series 6000-15000 A acc. to catalogue pages 35 and 36

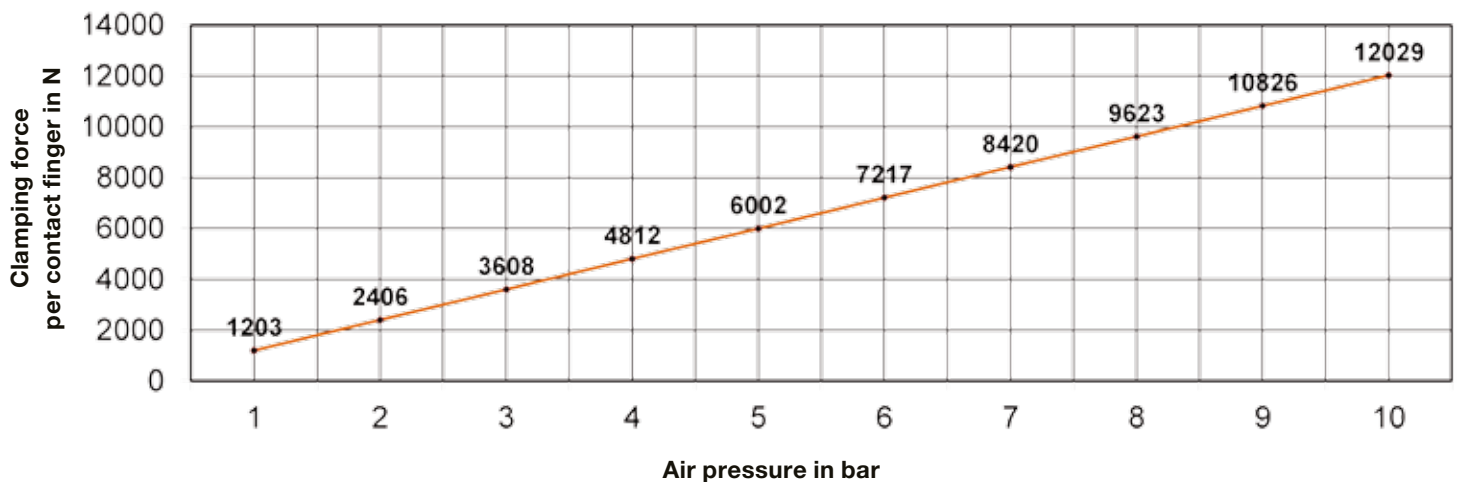

At an air pressure of 6 bar, the total contact pressure of one contact saddle reaches the following values:

Model 6000 A = approx. 57,7 kN

Model 8000 A = approx. 72,2 kN

Model 10000 A = approx. 101,0 kN

Model 12000 A = approx. 115,5 kN

Model 15000 A = approx. 144,3 kN

Hydro-pneumatically actuated high current contact saddles

“druseidt-Titan”/Standard design 6000 - 15000 A

with 10 mm dimensional difference compensation

Standard versions

mounted on an E-copper plate

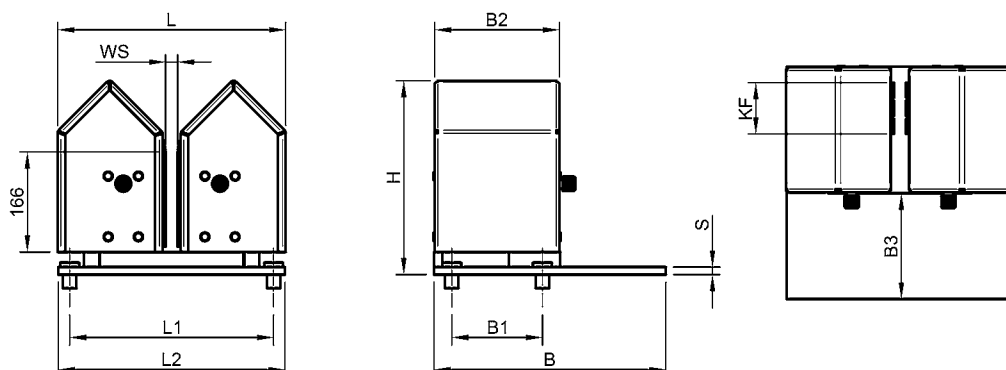

Part-No.	max. current load	Technical data										
		dimensions mm										
		L	L ₁	L ₂	B	B ₁	B ₂	B ₃	H	S	KF	weight kg/pcs.
25153	6000 A	342	285	320	410	2 x 90	228	180	318	15	112	96
25154	8000 A	342	285	320	439	2 x 110	257	180	323	20	141	115
25155	10000 A	342	285	320	549	2 x 145	337	210	328	25	199	156
25156	12000 A	342	285	320	578	2 x 160	366	210	338	30	228	181
25157	15000 A	342	285	320	652	3 x 230	440	210	343	35	286	211

Standard versions

mounted on an 90° angled E-copper-plate

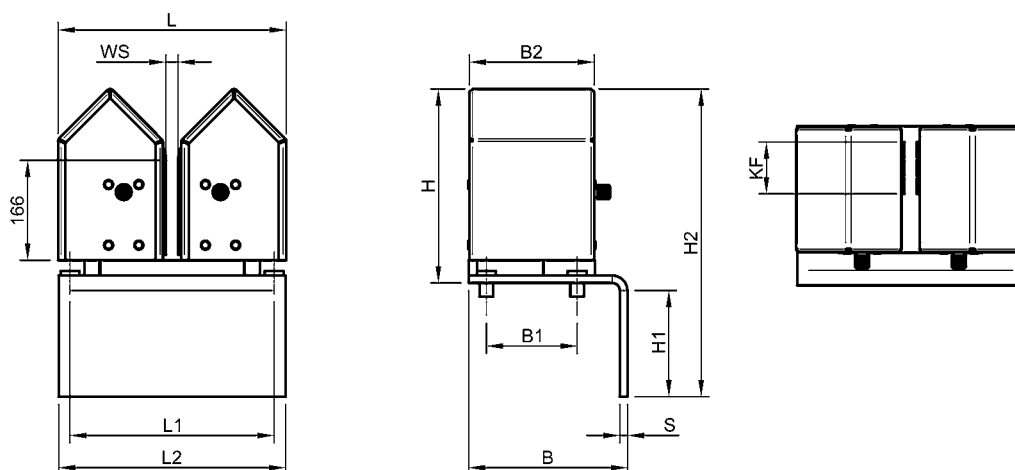

Part-No.	max. current load	Technical data											
		dimensions mm											
		L	L ₁	L ₂	B	B ₁	B ₂	H	H ₁	H ₂	S	KF	weight kg/pcs.
25253	6000 A	342	285	320	270	2 x 90	228	318	170	503	15	112	97
25254	8000 A	342	285	320	320	2 x 110	257	323	170	513	20	141	118
25255	10000 A	342	285	320	400	2 x 145	337	328	210	563	25	199	161
25256	12000 A	342	285	320	440	2 x 160	366	338	210	578	30	228	188
25257	15000 A	342	285	320	520	3 x 130	440	343	210	588	35	286	220

Note: The dimensions shown in the tables are based on a product carrier thickness of 20 mm. If the thickness of the product carriers deviates from this, the width dimensions and, if necessary, the thicknesses of the E-copper plates or angles change accordingly.

Minimum height of the product carriers 80/120 mm. For 80 mm or less than 120 mm high product carriers the contact units must be supplied with an additionally mounted copper filler piece as height compensation. On request, all contact saddles are also available with a PT 100 temperature sensor.

Hydro pneumatically actuated high current contact saddles „druseidt-Titan“/Compact design 6000 - 15000 A with 10 mm dimensional difference compensation

Compact design

mounted on an E-copper plate

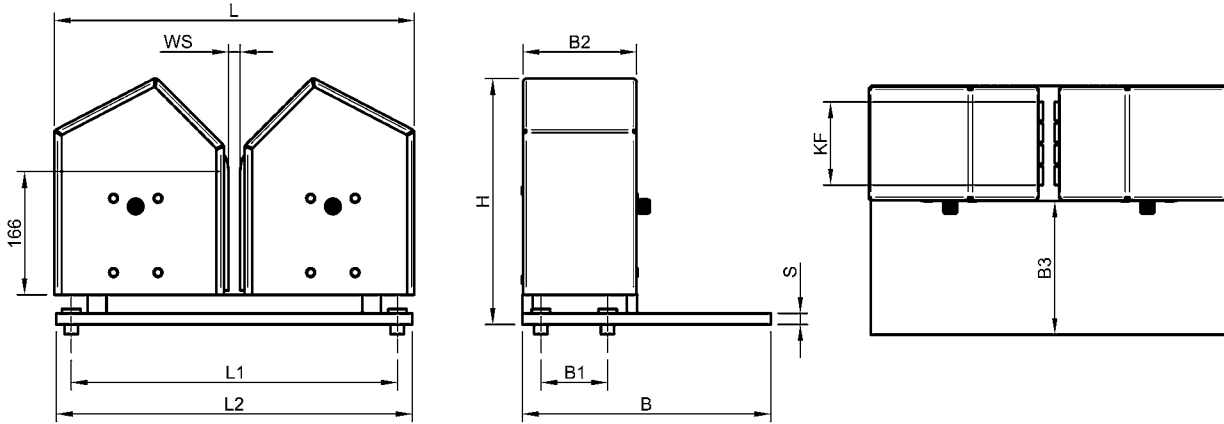

Part-No.	max. current load	Technical data										weight kg/pcs.
		dimensions mm										
		L	L ₁	L ₂	B	B ₁	B ₂	B ₃	H	S	KF	
25553	6000 A	482	440	480	335	1 x 90	153	180	331	15	112	118
25554	8000 A	482	440	480	364	2 x 67	182	180	331	15	141	133
25555	10000 A	482	440	480	452	2 x 96	240	210	336	20	199	185
25556	12000 A	482	440	480	481	2 x 110,5	269	210	341	25	228	210
25557	15000 A	482	440	480	539	3 x 93	327	210	341	25	286	247

Compact design

mounted on an 90° angled E-copper plate

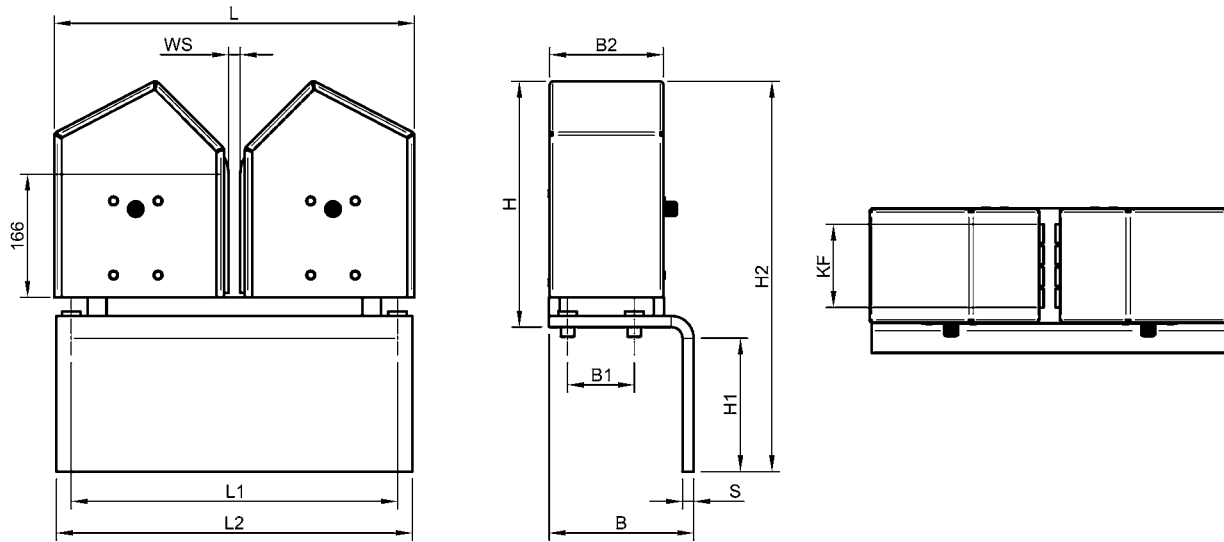

Part-No.	max. current load	Technical data											weight kg/pcs.
		dimensions mm											
		L	L ₁	L ₂	B	B ₁	B ₂	H	H ₁	H ₂	S	KF	
25653	6000 A	482	440	480	195	1 x 90	153	331	180	526	15	112	121
25654	8000 A	482	440	480	234	2 x 67	182	331	180	526	15	141	137
25655	10000 A	482	440	480	302	2 x 96	240	336	210	566	20	199	190
25656	12000 A	482	440	480	331	2 x 110,5	269	341	210	576	25	228	218
25657	15000 A	482	440	480	389	3 x 93	327	341	210	576	25	286	254

Note: The dimensions shown in the tables are based on a product carrier thickness of 20 mm. If the thickness of the product carriers deviates from this, the width dimensions and, if necessary, the thicknesses of the E-copper plates or angles change accordingly.

Minimum height of the product carriers 80/120 mm. For 80 mm or less than 120 mm high product carriers the contact units must be supplied with an additionally mounted copper filler piece as height compensation. On request, all contact saddles are also available with a PT 100 temperature sensor.

Pneumatically actuated plate contact systems and control modules

Designs and current loads

We manufacture pneumatically actuated plate contacts as standard as druseidt compact model 2500 for currents up to 3000 A or compact model 3000 for currents up to 12000 A. These plate contacts were developed decades ago by druseidt and always further developed in the course of time. They are a simply, compact and inexpensive solution and are suitable for the transmission of especially high currents or light product carriers.

Advantages and design features

- **Current transfer:**
Via honeycomb/nub-like milled contact surfaces that increase the contact surface for current transmission
- **Robust:**
Stable support construction and protective covers made out of A4 stainless steel
- **Compact:**
Small installation dimensions even when working with high currents
- **Pneumatic drive:**
Protected pneumatic cushions built into the contact units
- **Optional water-cooling:**
Standard for contact saddles from 4000 A current load
- **Repair friendly:**
Only a small number of components that can be easily replaced

Design features

In terms of contact pressure they are limited to the pressure capacities of the used pneumatic cushions. Compared to the possibly contact pressure of both our pneumatic bolt and hydro-pneumatic actuated contact systems, they therefore achieve only a fraction of their pressure performance.

Problems can arise with product carriers that are warped in the contact area, as the contact plates cannot then adjust accordingly, as in the case with individually pneumatically actuated contact fingers or bolts. Only a part of the possible contact surface of the product carrier is then in contact with the contact surfaces of the contact units. The degree of contamination and cleaning intervals are also very different in the individual plants. Although all contact saddles are cross-sectionally designed for the specified rated current, heating problems can still occur. We have therefore equipped all contact saddles of the compact Model 3000 series suitable for currents from 4000 A with additional water-cooling as standard. This can then be optionally switched on in the event of a problem.

Control modules

As accessories for all pneumatic or hydro-pneumatic systems, we also supply control modules that enable the user to use pneumatically or hydro-pneumatically actuated contact saddles, without having to intervene in the existing bath control system.



Pneumatically actuated plate contacts up to 3000 A

System druseidt - Compact Model 2500

This contact system developed by druseidt, is an extremely robust design. In the standard version, the contact consists of a fixed contact jaw with rigid connection to the power supply system and a moveable pneumatically actuated, spring-mounted clamping jaw that does not require connection to the power supply system.

Both the sturdy base body and the protective covers are made of A4 stainless steel and offer good mechanical as well as chemical resistance. The contact surfaces available for current transmission are milled in a honeycomb/nub-like manner. The pneumatic drive works via a so called pneumatic cushion which is built into the contact unit and protected from aggressive media.

With this system, there is no need for a space consuming pneumatic cylinder that may be susceptible to damage through the media. These druseidt contact saddles have a space-saving compact design and can also be used in confined spaces.

The pneumatic cushions are offered as spare parts and can be easily displaced if necessary. In the standard design, the contact saddles are supplied either with a straight E-copper connection bar protruding to the front or with 90° angled connection bar. Alternatively a delivery with longer connection bars is also possible on request. The air pressure required for operation should be at least 4-6 bar. The required air volume is extremely low at approx. 0,2 litres per gear change.

The contact saddles can be operated with pneumatic hand switches as well as integrated into existing pneumatic controls or with a druseidt control module as described on page 42.

As there is no spring resistance to overcome when inserting the product carriers, these contact saddles are also excellently suited for contacting extremely light product carriers, e.g. within plastic electroplating plants.

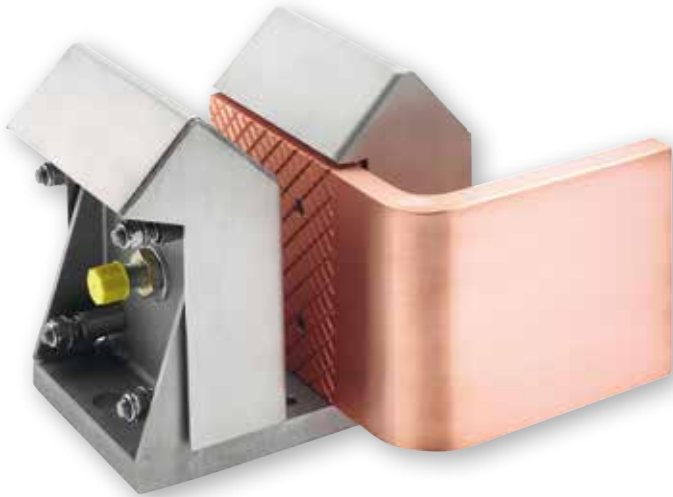

Standard design
with 90° angled connection bar

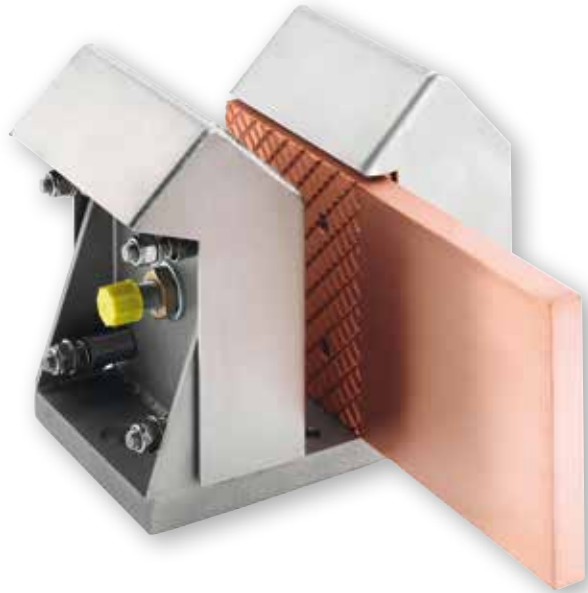

Standard design
with straight connection bar



Splash-proof sealed highly flexible PVC-insulated
copper connectors

Pneumatically actuated plate contacts up to 3000 A

System druseidt – Compact Model 2500

Material of the base body and protective covers A4 stainless steel

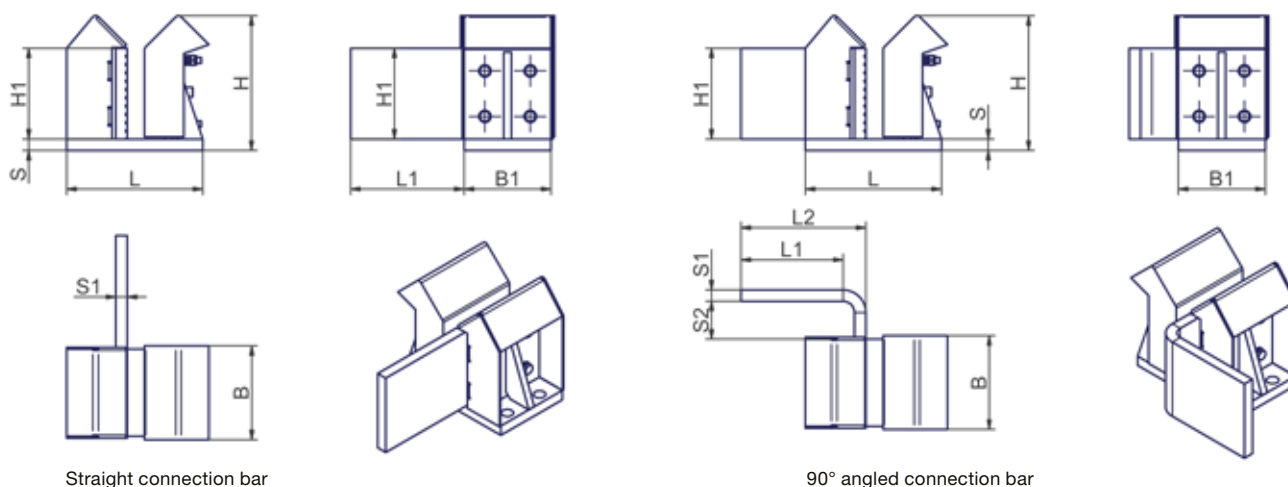

Straight connection bar

90° angled connection bar

Part-No.				Technical data												
straight connection bar left	straight connection bar right	90° angled connection bar left	90° angled connection bar right	suitable for product carrier max. current load	product carrier height mm	dimensions mm										
						L	L ₁	L ₂	B	B ₁	B ₂	H	H ₁	S	S ₁	S ₂
25700-L	25700-R	25700-L 90	25700-R 90	2000 A	80 - 120	180	150	165	124	115	65	178	120	15	15	50
25800-L	25800-R	25800-L 90	25800-R 90	3000 A	80 - 120	180	135	175	124	115	70	178	120	15	20	50

31111 Replacement pneumatic cushion

31115 Temperature sensor PT 100, cable 2 m long, PFA-insulated, 4 wire technology

Note: To ensure that the contact saddles can be universally adapted to the installation situation and above all, that they press in the same direction when current is fed in from both sides, all designs are available with a connection bar on the left as well as on the right. All versions can also be supplied with a temperature sensor PT 100 or an additional insulating plate.

Other cable lengths or insulation material for the temperature sensor on request. The maximum product carrier thickness of these contact saddles is 25 mm or 1". The contact saddles are supplied factory-set to the dimension of the existing product carriers. For higher or lower product carriers than indicated in the table, a consultation with us is required. **In case of an order, please always state the thickness and height of your product carrier.**

Highly flexible connectors

Suitable for connecting our pneumatically actuated plate contacts Compact Model 2500

Although the power supply to the contact saddles of the compact 2500 series can be made via the fixed side by means of solid busbars, it can still be an installation advantage to connect them with highly flexible current connectors. For this purpose, we offer e.g. the following highly flexible PVC-insulated round stranded connectors in splash-proof sealed design. On request, other flexible connection options are of course also possible, e.g. with flat stranded connectors or similar designs. With pleasure we'll advice you on your applications.

Connection options for the different current strengths

When using contact saddle			
Part-No.	current load	suitable connectors	
25700	1000 A	1 x 600 mm ²	Best.-Nr. 25960
25700	1500 A	1 x 1000 mm ²	Best.-Nr. 25966
25700	2000 A	2 x 600 mm ²	Best.-Nr. 25960
25800	2500 A	2 x 750 mm ²	Best.-Nr. 25962
25800	3000 A	2 x 1000 mm ²	Best.-Nr. 25966

Part-No.	Technical data						
	cross-section mm ²	A	B	D	E	F	S
25960	600	80	55	14	20	40	18,8
25962	750	80	55	14	20	40	21,8
25964	850	80	55	14	20	40	22,3
25966	1000	80	55	14	20	40	26,9

Note: Lengths individually according to customer requirements

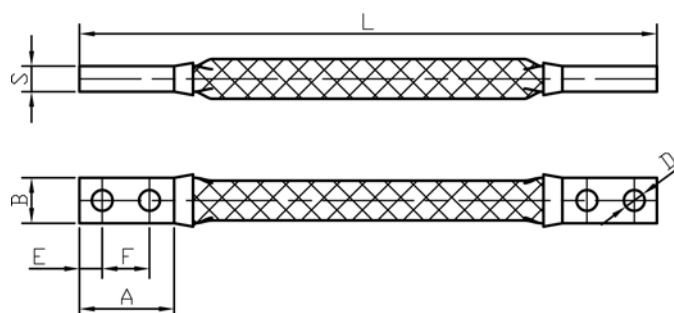

Pneumatically actuated plate contacts 4000 - 12000 A

System druseidt - Compact Model 3000
with water cooling option as standard

Pneumatically actuated high current contact saddles of the druseidt series Compact Model 3000 are used due to the extremely stable construction especially in the area of high currents and heavy product carriers (e.g. within anodizing and hard chrome plating plants). The base plate as well as the protective covers are manufactured out of rust and acid resistant A4 stainless steel material. The current is transmitted in both sides via honeycomb/nub-like milled E-copper contact surfaces.

The pneumatic drive operates via pneumatic cushions installed on one or on both sides which are built into the contact unit in a protected manner. The contact saddles are connected to the power supply system via E-copper connection busbars provided on both sides. The moveable contact saddle side must be connected with flexible current connectors or cables.

The non-moving side can be connected with solid busbars or, if advantageous, also with flexible connectors or cables.

On Request, all contact saddles are also available with longer or straight connection busbars. All standard contact saddles can be supplied with a temperature sensor PT 100 as well as with an additionally mounted insulating plate. Only 4 holes are required for mounting on the tank rim. The air pressure required for operation should be 4-6 bar.

The contact saddles can be operated with pneumatic hand-witches as well as integrated into existing pneumatic controls or with a druseidt control module as described on page 42.

Optional water-cooling possibility

Although the contact saddles offered are cross-sectionally designed for the specified rated current, all contact units of the Compact Model 3000 Series are equipped with an additional water cooling option as standard. This cooling option can then be optionally switched on if necessary for particularly heavily stressed contact saddles, older/warped product carriers or heavily soiled systems.

Since the water cooling goes completely through the connection angle, not only the contact point to the product carrier is cooled, but also the connection point to the power supply system. In this way, excessive contact heating can be reliably prevented.



Contact saddle in standard design



Replacement pneumatic cushions
Part-No. 31111 and 37777



Splash-proof sealed highly flexible
PVC-insulated copper connectors

Pneumatically actuated plate contacts 4000 - 12000 A

System druseidt – Compact Model 3000

with water cooling option, base plate and protective covers made out of A4 stainless steel

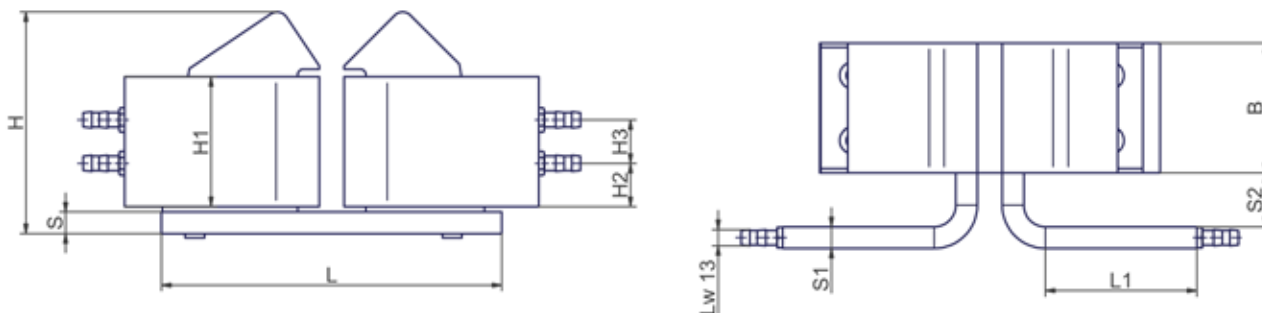

Part-No.			Technical data												
one-sided left	one-sided right	on both sides	current load	suitable for product carrier height mm	dimensions mm										
					L	L ₁	B	H	H ₁	H ₂	H ₃	S	S ₁	S ₂	
25900-L	25900-R	25900-B	4 - 6000 A	80 - 120	315	140	120	205	120	40	40	20	20	50	
25920-L	25920-R	25920-B	6 - 8000 A	140 - 200	350	220	215	301	200	40	120	20	20	50	
25940-L	25940-R	25940-B	10 - 12000 A	140 - 200	370	300	215	301	200	40	120	20	25	50	
31111 Replacement pneumatic cushion for contact saddles of the series 25900															
37777 Replacement pneumatic cushion for contact saddles of the series 25920/25940															
31115 Temperature sensor PT 100, cable 2 m long, PFA-insulated, 4-wire technology															
<p>Note: To ensure that the contact saddles can be universally adapted to the installation situation and above all, that they press in the same direction when current is fed in from both sides, all designs are available with pneumatic operation on the left, right as well as on both sides. All contact saddles are already provided with a connection hole for a temperature sensor on the pneumatically actuated sides as a standard feature. The temperature sensor can either be supplied by us directly mounted at the factory or it can later be supplied and mounted by the customer without any problems.</p>								<p>The contact saddles can be supplied also with an additionally mounted insulation plate. Other cable lengths and insulation than specified in the table for the temperature sensor on request. The dimension L in the table is given for a product carrier thickness of 20 mm and changes accordingly for thicker product carriers. The contact saddles are supplied adjusted to the existing product carrier dimensions at the factory. In case of an order please indicate the thickness and height of the product carrier. For higher or lower product carrier dimensions than indicated in the table, a consultation with us is required.</p>							

Highly flexible connectors

suitable for connecting our pneumatically actuated plate contacts
Compact Model 3000

When working with our pneumatically actuated contact saddles of the Compact Model 3000 series, the pneumatically actuated side must be connected with flexible current connectors or cables. For the designs with pneumatic actuation on one side, the second side can be rigidly connected by means of solid busbars. For this purpose, we offer the following highly flexible PVC-insulated round stranded connectors in splash-proof sealed design.

On request, other flexible connection options are of course also possible, e.g. with flat stranded connectors or similar designs. With pleasure we'll advice you on your applications.

Connection options for the different current strengths

Part-No.	current load	suitable connectors with one/two-sided pneumatic actuation	Best.-Nr.
25900	4000 A	2/4 x 600 mm ²	25960
25900	5000 A	2/4 x 750 mm ²	25962
25900/920	6000 A	2/4 x 1000 mm ²	25966
25920	8000 A	3/6 x 1000 mm ²	25966
25940	10000 A	4/8 x 850 mm ²	25964
25940	12000 A	4/8 x 1000 mm ²	25966

Part-No.	Technical data						
	cross-section mm ²	A	B	D	E	F	S
25960	600	80	55	14	20	40	18,8
25962	750	80	55	14	20	40	21,8
25964	850	80	55	14	20	40	22,3
25966	1000	80	55	14	20	40	26,9

Note: Lengths individually according to customers requirements.

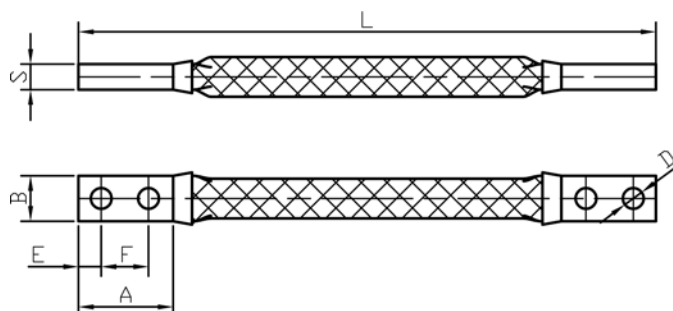

Control modules for pneumatically resp. hydro-pneumatically actuated contact systems

These control modules developed by druseidt automatically switch the air pressure required for actuating pneumatically resp. hydro-pneumatically operated contact systems on and off when the bath current is switched on.

With these control modules, the user is able to use pneumatically actuated contacts at any point in the bath without having to intervene in the existing bath control system.

When using version II = Part-No. 36101 it is not even necessary to install or have an external compressed air supply. A 220 V socket is sufficient to be able to work with pneumatically/hydro-pneumatically actuated contact saddles. This makes it possible, for example, to easily replace spring-loaded contact saddles with a pneumatically/hydro-pneumatically system at critical points where they have previously led to heating problems. Individual baths can also be tested first to see whether pneumatically/hydro-pneumatically actuated contact saddles bring advantages without having to convert an entire plant system or change the control system.



Available designs

Part-No. 36100

Design I: without integrated air supply. That means a compressed air supply that is already available at the bath is used.

Part-No. 36101

Design II: with integrated air supply. That means it is possible to work completely independent of external compressed air.

druseidt control modules enable

- a high degree of flexibility
- an optimal adaptation of pneumatically/hydro-pneumatically actuated contact saddles to the systems
- working without an external compressed air supply (Part-No. 36101)
- a simple, unproblematic but extremely effective handling

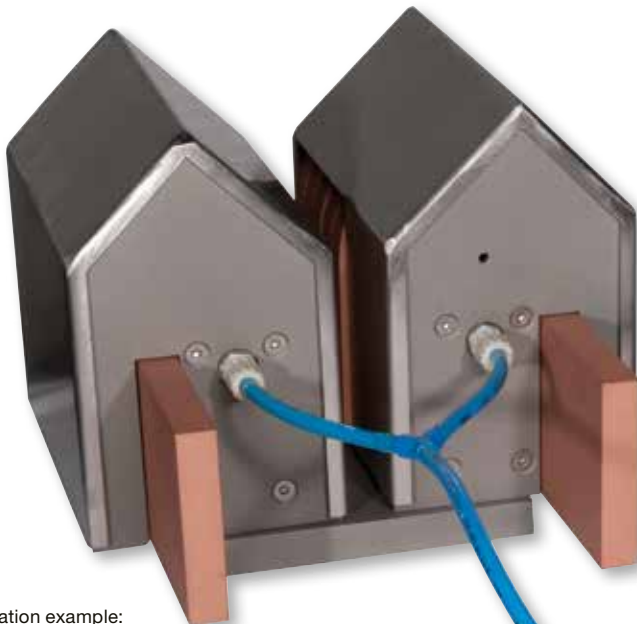

Application example:
Control module
in connection with
Titan-contact saddle



druseidt cleaning systems for finger contact saddle systems and product carriers

optimal complement to our current carrying contact systems

Our cleaning systems enable a significant reduction in performance losses and help to optimize the process flow and minimize repair and maintenance costs. We deliver as standard:

- druseidt hand cleaner for quick cleaning of druseidt finger contact saddles (can also be used in the running process)
- druseidt hand cleaner for the surface cleaning of busbars
- cleaning carrier for cleaning of finger contact saddles (can be integrated in automated processes)
- druseidt cleaning saddles for the automated continuous cleaning of contact surfaces on product carriers (can be fitted e.g. for the non-current carrying support blocks in the area of the rinsing baths).

ATTENTION!

Dirty contact saddles and contact surfaces mean:

- higher contact resistances
- higher electrical losses
- higher heatings
- higher repair and maintenance costs



Hand cleaner
for busbars/surface cleaning



Cleaning slider for contact saddles/
two hand operation

Cleaning slider for contact saddles/
one hand operation



Cleaning carrier
for contact saddle cleaning

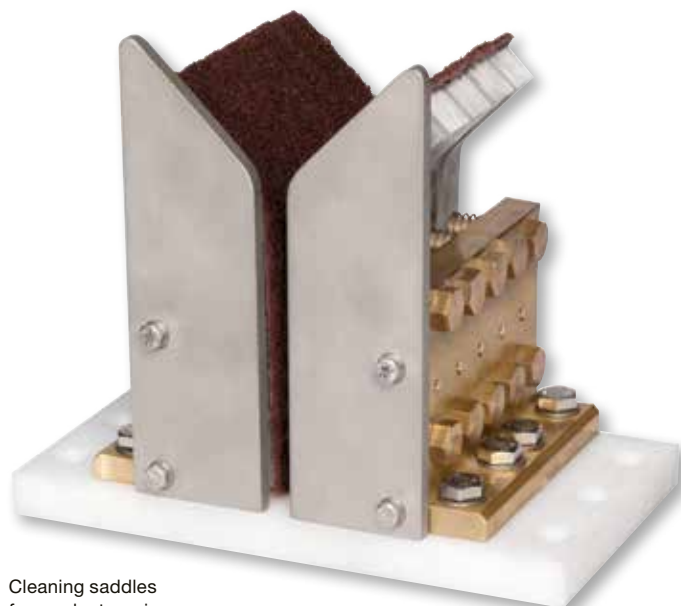

Cleaning saddles
for product carriers

druseidt hand cleaning sliders and cleaning carriers

Cleaning sliders enable a cost-efficient and effective cleaning of the contact surfaces of our standard finger contact saddles as well as those of comparable competitor products. They are dimensionally designed for the product carriers used. Depending on the size of the contact saddles to be cleaned, a version for both one-hand and two-hand operation is available.

Cleaning sliders for contact saddles acc. to catalogue pages 8-13

Cleaning slider one-hand operation	Cleaning slider two-hand operation	suitable for product carrier thickness
Part-No.	Part-No.	
36030-10	36040-10	10 mm
36030-12	36040-12	12 mm
36030-15	36040-15	15 mm
36030-20	36040-20	20 mm
36030-25	36040-25	25 mm

Note: Cleaning sliders for other product carrier thicknesses on request.

Cleaning sliders for contact saddles with variable product carrier thicknesses acc. to catalogue pages 14-17

Part-No.	
36015	Cleaning slider for one-hand operation
36020	Cleaning slider for two-hand operation

Hand cleaning slider for surface cleaning Part-No. 36110

A cost-effective solution for a simple but effective cleaning of busbars or larger power transmission surfaces.

Cleaning carriers

In order to be able to integrate the cleaning of the contact surfaces of our high current finger contact saddles directly into the automatized system process, we offer the production of cleaning carriers individually adapted to the existing systems and plants. These cleaning carriers are fitted with replaceable cleaning rails or end pieces at the ends. These end pieces are coated with our special cleaning fleece and are dimensionally matched to the contact saddles used. Depending on the degree of contamination, it is thus possible to run a cleaning cycle once a day, per shift or at any other interval. By moving the cleaning carriers in and out of the contact saddles several times, the surfaces are cleaned and thus enable optimized current transmission, even in systems with a higher degree of contamination.

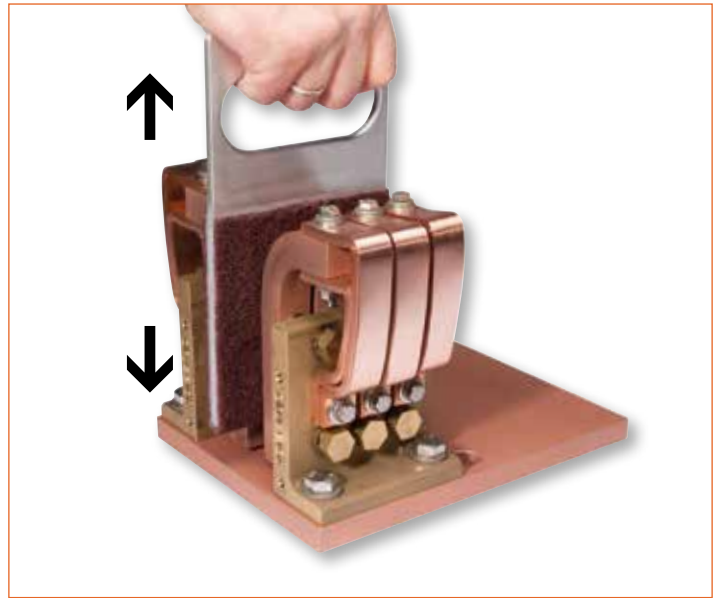

Cleaning process, one-hand operation



Cleaning process, busbar or surface cleaning



Application example for a design of a cleaning carrier

druseidt cleaning saddles for product carriers

System description

druseidt cleaning saddles are based on the principle of our spring loaded finger contact saddles and are equipped with a special cleaning fleece on the contact surfaces. This special material makes it possible to clean the contact surfaces of the product carriers by moving them in and out.

The material used is extremely resistant to chemicals and can be cleaned by blowing it out with a compressed air gun. Both laboratory and practical tests have led to very good results and service lives. In case of wear, the halves of the cleaning saddles, offered as spare parts, can be exchanged without any problems.

In order to achieve an optimal cleaning effect, the cleaning saddles are adjusted to the thickness of the existing product carriers. By mounting the cleaning saddles instead of the non-current carrying support blocks, e.g. in the area of the rinsing baths they will be integrated into the fully automated system process.

The cleaning saddles listed as standard are dimensionally matched to the different contact systems listed in this catalogue. In addition to this, special designs adapted to other product carrier dimensions or other contact systems are also possible.

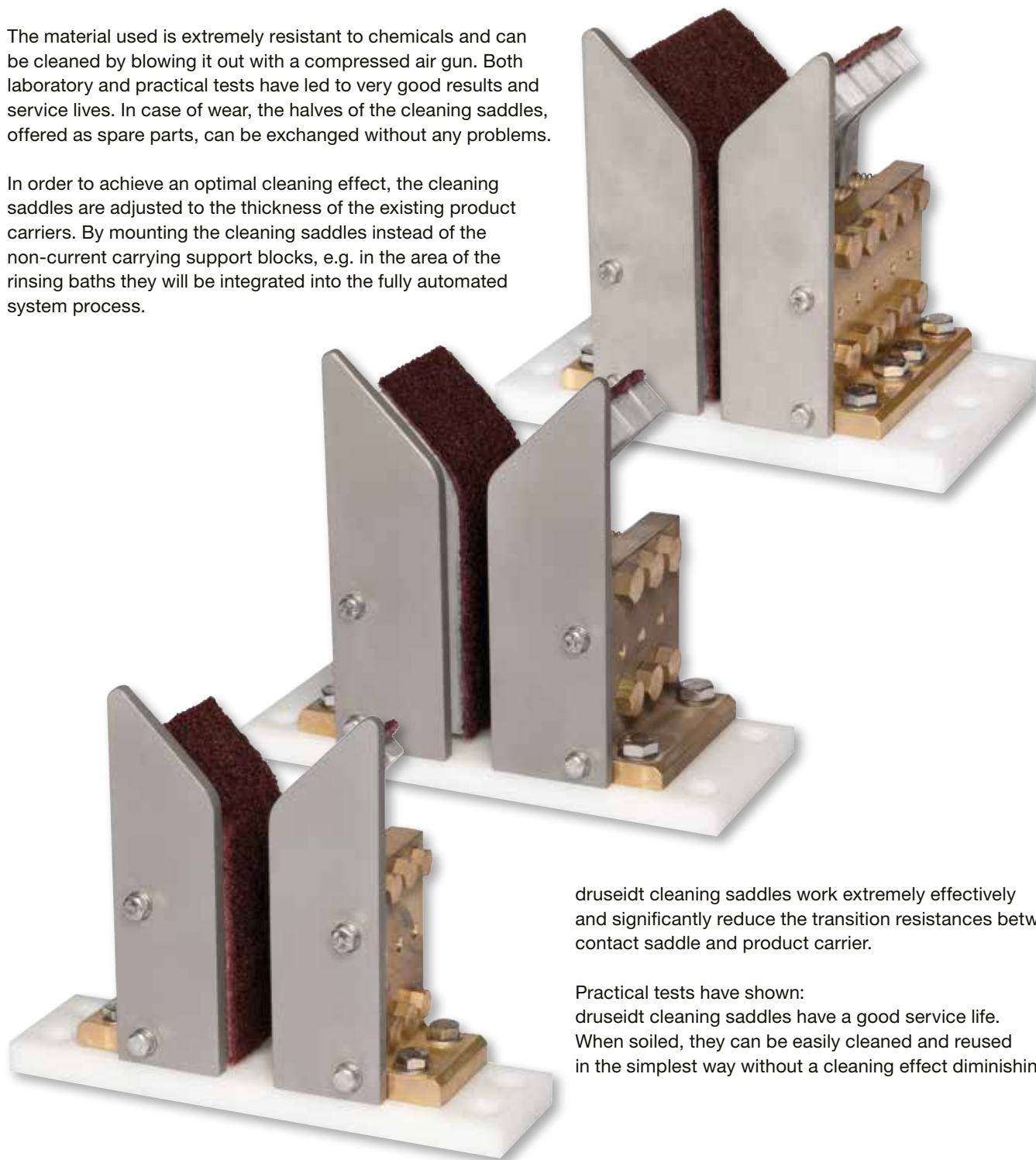

druseidt cleaning saddles work extremely effectively and significantly reduce the transition resistances between contact saddle and product carrier.

Practical tests have shown:
druseidt cleaning saddles have a good service life.
When soiled, they can be easily cleaned and reused in the simplest way without a cleaning effect diminishing.

druseidt cleaning saddles for product carriers

dimensionally adapted to druseidt finger contact saddles

acc. to catalogue pages 8-17

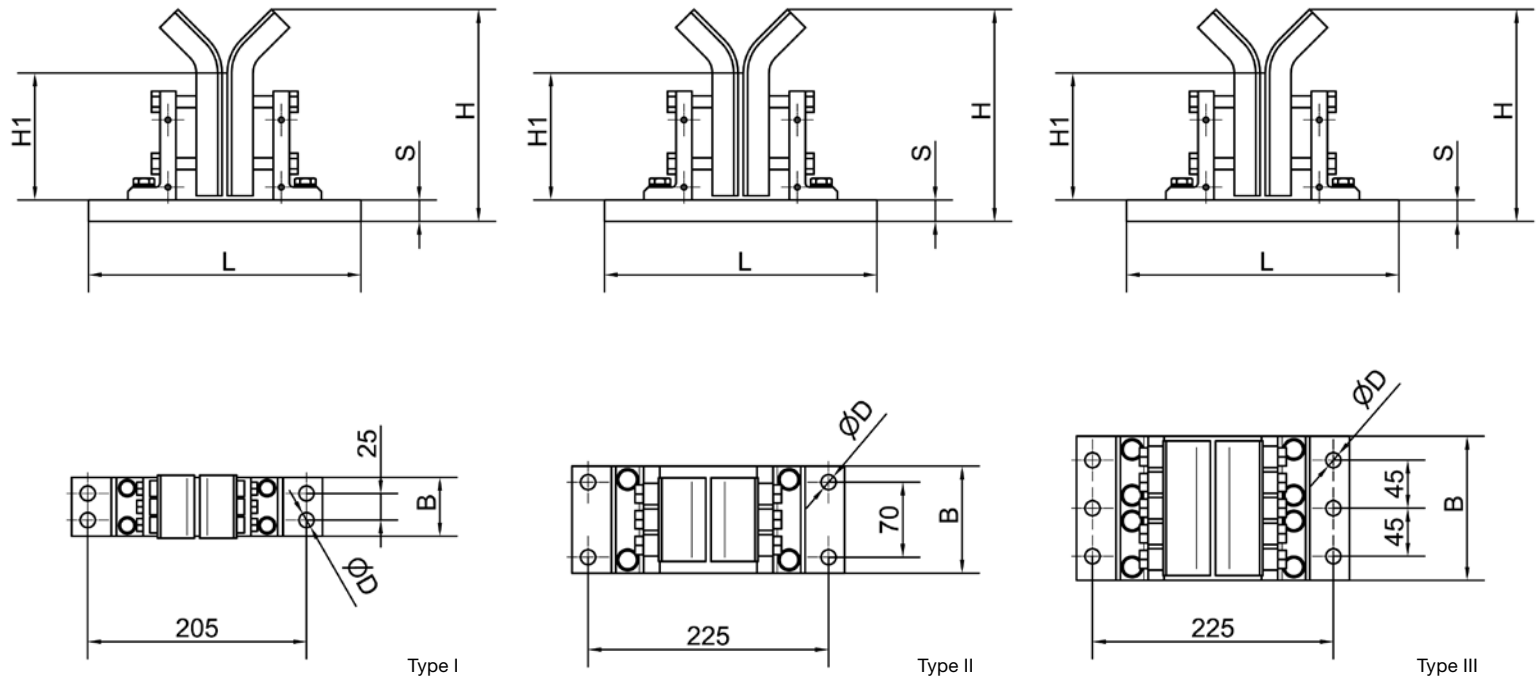

Part-No.		Technical data								
cleaning-saddle, complete	one exchange half complete/spare part	Type	suitable for product carrier		dimensions mm					
			thick-ness	height	L	B	H	H1	S	D
36000-10	36000-A	I	10	100	235	63	165	106	15	14
36000-15			15							
36000-20			20							
36005-10	36005-A	II	10	120	255	108	195	119	15	14
36005-15			15							
36005-20			20							
36010-10	36010-A	III	10	120	255	143	200	119	20	14
36010-15			15							
36010-20			20							

Note: The cleaning saddles are dimensionally adapted for parallel use with our high current finger contact systems acc. to catalogue pages 15 and 17 and dimensionally comparable finger contact saddles acc. to catalogue pages 8-13. Cleaning saddles for other product carrier thicknesses or other contact saddles on request

druseidt cleaning saddles for product carriers

dimensionally adapted to druseidt high current contact series "Titan"

acc. to catalogue pages 32-36

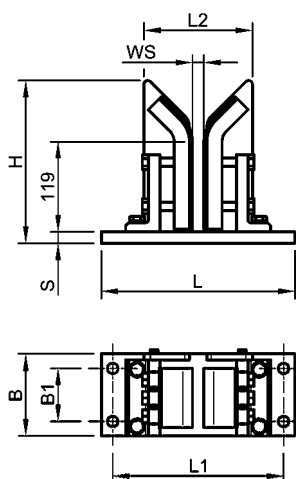

Part-No. 36005-20

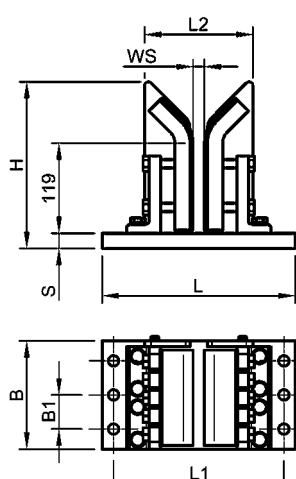

Part-No. 36010-20

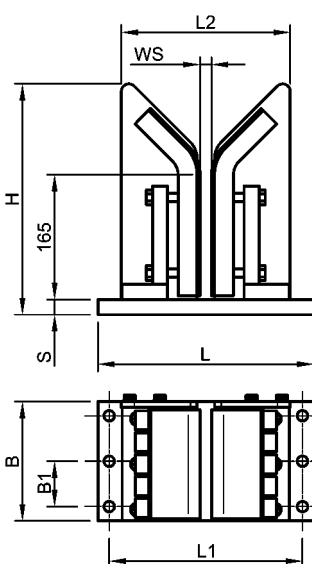

Part-No. 36053-20/36054-20

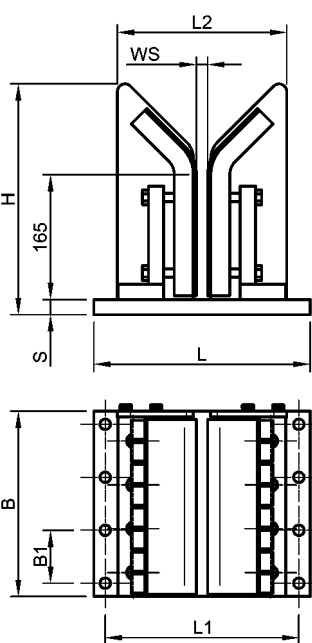

Part-No. 36055-20/36056-20

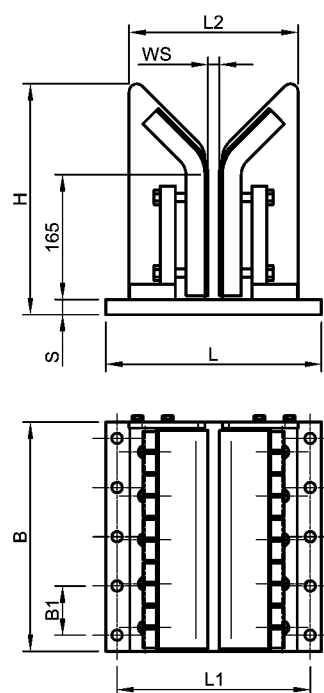

Part-No. 36057-20

Part-No.		Technical data								
cleaning saddle complete	one exchange half complete/spare part	suitable together with Titan contact, current load	dimensions mm							
			L	L ₁	L ₂	B	B ₁	H	S	weight kg/pcs.
36005-20	36005-A	3000 A	255	225	143	108	1 x 70	215	15	7
36010-20	36010-A	4000 A/5000 A	255	225	143	143	2 x 45	220	20	10
36053-20	36053-A	6000 A	285	255	233	129	2 x 45	305	20	16
36054-20	36054-A	8000 A	285	255	233	158	2 x 60	305	25	19
36055-20	36055-A	10000 A	285	255	233	216	3 x 60	305	20	25
36056-20	36056-A	12000 A	285	255	233	245	3 x 70	305	20	28
36057-20	36057-A	15000 A	285	255	233	303	4 x 65	305	20	34

Note: The cleaning saddles are dimensionally adapted for parallel use with our high current contact saddles of the Titan-series acc. to the catalogue pages 32-36 or similar contact systems. The dimensions listed in the table are based on a product carrier thickness of 20 mm. If the thickness of the product carriers deviates from this, the width dimensions change accordingly.

Therefore, in case of an order, please specify the height and thickness of your product carrier.

druseidt cleaning saddles

The optimal complement to our current-carrying contact systems

druseidt cleaning saddles are extremely effective and significantly reduce the transition resistances between the contact saddles and the product carriers.

Before the first use the contact surfaces on the product carriers must be thoroughly cleaned.

In the following operation, the contact surfaces of the product carriers are permanently cleaned. Soiled cleaning saddles are cleaned by blowing them off with compressed air or in case of stubborn soiling, with a wire brush under running water.

In case of wear/destruction of the cleaning fleece replace with the cleaning saddle halves offered as spare parts and send the damaged halves for repair back to us.

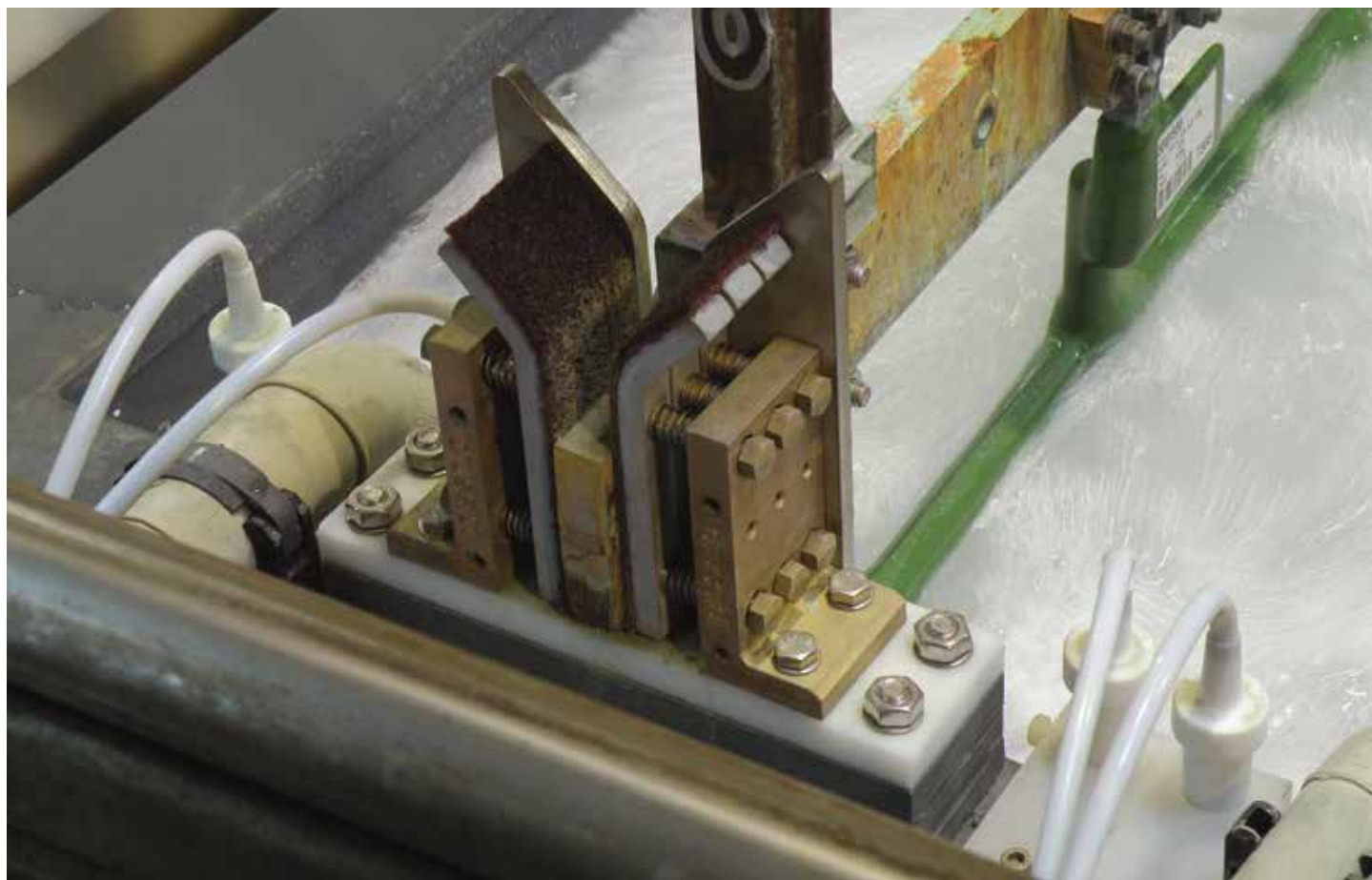

Practical tests have shown: druseidt cleaning saddles have a good service life and can be cleaned and reused in the simplest way when soiled without a cleaning effect diminishing.

In combination with our innovative druseidt contact systems, we thus achieve an optimized efficiency and cost-effectiveness.

Contacts 500 - 2500 A

for contacting busbars and anode rails

This robust contact system is particularly suitable for contacting that do not have to be permanently moved in or out.

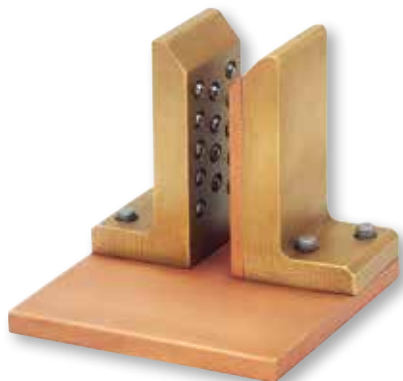

The contact surface is nub-like designed for improved current transmission. The contact pressure is generated via spring-mounted replaceable stainless steel balls. The contacts are supplied mounted on an E-copper plate and adjusted to the existing busbar or anode rail dimensions. Therefore when ordering please specify the height and thickness of your busbar/anode rail.

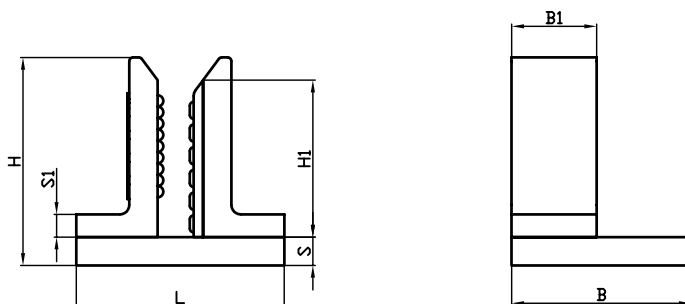

Part-No.	Technical data									
	max. current load	suitable busbar height mm	dimensions mm							weight kg/pcs.
			L	B	B ₁	H	H ₁	S	S ₁	
17047	500 A	50 - 100	105	90	40	100	80	10	12	3,00
17049	1000 A	50 - 100	105	110	60	100	80	10	12	4,50
17051	1500 A	80 - 120	105	140	80	100	80	15	12	6,00
17053	2000 A	80 - 120	105	180	100	100	80	20	12	7,50
17055	2500 A	80 - 120	105	220	120	100	80	20	12	9,00

Spare parts:
 17057 Spring-loaded stainless steel balls incl. screws

Note: The dimension L in the table is based on the use of a 10 mm thick busbar or anode rail and changes accordingly for thicker rails. **Therefore when ordering please specify the height and thickness of your busbar/anode rail.**

Quick release contacts

for contacting busbars and anode rails

For systems where the busbar or anode rail are retracted by hand, we manufacture quick release contacts in a relatively small, compact design, e.g. with copper connection bar 80 x 15 mm in variable lengths or angled designs.

The contact-/clamping surface is honeycomb/nub-like milled in order to increase the contact surface for current transmission.

The clamping process is carried out by simply operating the clamping lever (approx. 1/4 turn) and presses the busbar/anode rail against the contact surface with great pressure.

The clamping force is transmitted via the clamping lever by means of a stainless steel pressure plate. The spring-loaded clamping lever is made of a special alloy and can be adjusted in any position after the clamping process is finished so does not interfere with the bath. To protect the contact against chemical splashes, we can also supply an additional plastic cover on request. Further informations are available on request and we are happy to advise you on your applications.



Quick release contact/application example, mounted on a PP-base plate 120 x 20 x 150 mm



Quick release contact/application example with additional plastic cover

Prism support blocks

Material: PE 500

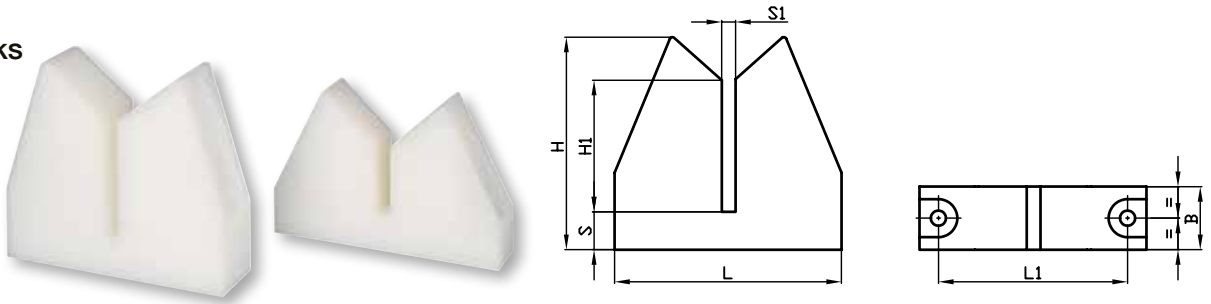

Part-No.	max. product carrier height	Technical data								weight kg/pcs.
		dimensions mm								
		L	L ₁	B	H	H ₁	S	S ₁	drilling-Ø	
51135	60	180	150	40	130	60	30	acc.	12	0,45
51136	120	180	150	50	170	100	30	to your	12	0,80
51137	160	220	190	60	210	140	40	specification	12	0,95
51138	200	220	190	60	250	180	40		12	2,45

Note: Prism support blocks are used to hold busbars inside of all non-current-carrying baths, loading and unloading stations etc. They are made out of wet-coloured solid PE 500 as standard, resulting in a stable design. On request, all versions can also be made by other materials or in other dimensions. Dimension S1 and if applicable, dimension L/L1 can be changed depending on the product carrier thickness. **Therefore when ordering please specify the thickness of your product carrier.**

Prism support blocks

Material: Brass casting

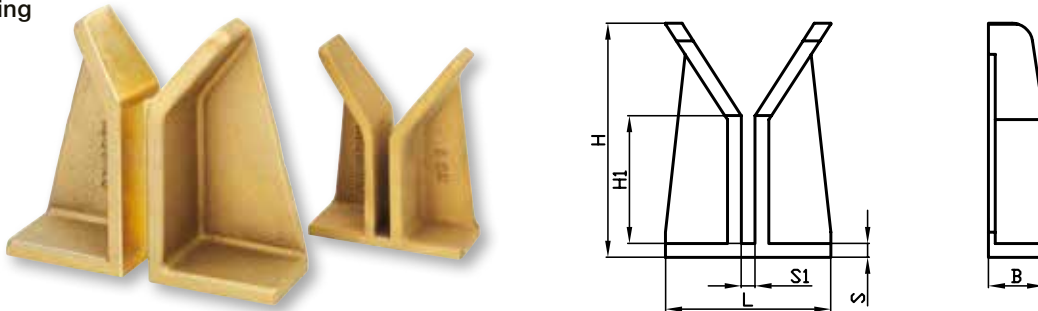

Part-No.	max. product carrier height	Technical data						weight kg/pcs.
		dimensions mm						
		L	B	H	H ₁	S	S ₁	
51040	60	120	40	110	40	10	12	1,50
51050	120	120	50	160	85	10	12	2,00
51065	200	100	65	200	130	15	-	5,70

Note: Robust design. Particularly suitable for holding heavy product carriers.

Part-No. 51040/50 one-piece models for product carrier thickness 10 mm.

Part-No. 51065 consists of two halves that are not connected to each other and can thus be mounted to match the respective existing product carrier thickness.

Prism support blocks

Material: Plastic

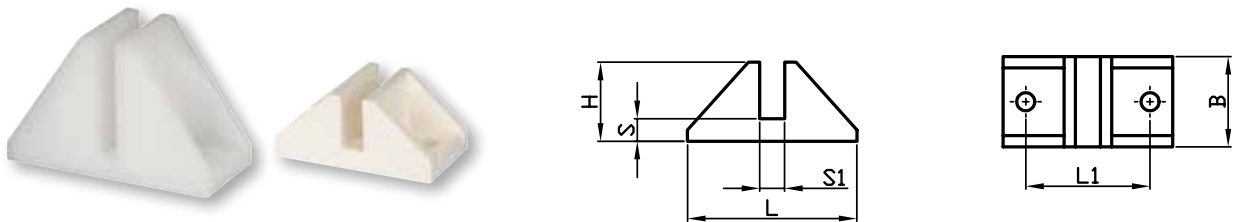

Part-No.	for product carrier	Technical data							weight kg/pcs.
		dimensions mm							
		L	L ₁	B	H	S	S ₁	drilling-Ø	
54100	50 x 5	75	55	40	35	10	6	8,5	0,05
54105	50 x 10	75	55	40	35	10	11	8,5	0,04
54106	100 x 10	100	70	40	67	10	11	8,5	0,10

Disconnecter switches

manually operated, for switching in loadless state

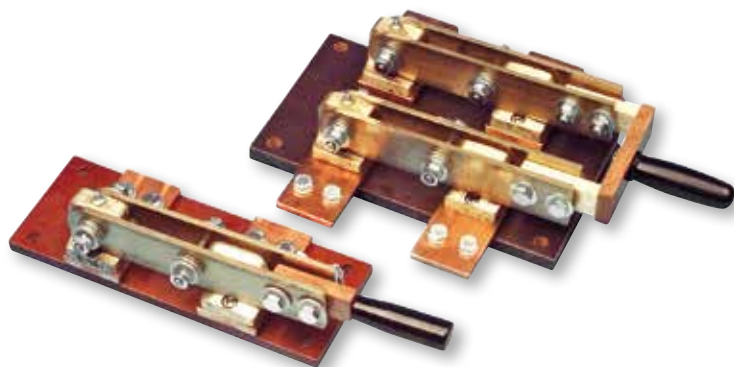

Disconnecter switches 1000 A, 1-pole and 2-pole design

Part-No. 1-pole	Part-No. 2-pole	max. current load
52160	52200	400 A
52165	52205	600 A
52170	52210	1000 A
52175	52215	2000 A
52180	52220	3000 A
52185	52225	4000 A

Disconnecter switches

pneumatically actuated, for switching in loadless state



Disconnecter switch 4000 A, 1-pole design

Part-No. 1-pole	Part-No. 2-pole	max. current load
52675	52680	1000 A
52676	52681	2000 A
52677	52682	3000 A
52678	52683	4000 A

Note: Compact relatively small switches in modular design. Can also be used for larger switching capacities above 10 kA by combining individual modules.

Reversing-/reversing pole switches

manually operated, for switching in loadless state

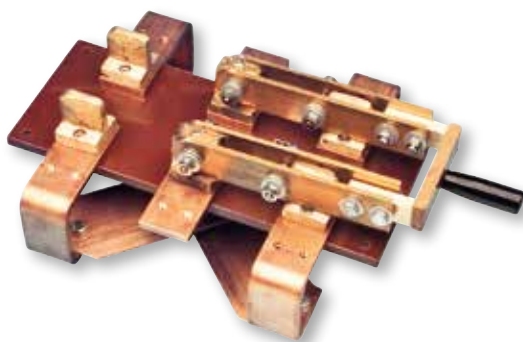

Reversing pole switch 1000 A, manually operated

Part-No. Reversing switch, 2-pole	Part-No. Reversing pole switch, 2-pole	max. current load
52245	52425	600 A
52250	52430	1000 A
52255	52435	2000 A
52260	52440	3000 A

Reversing-/reversing pole switches

motor operated, for switching in loadless state

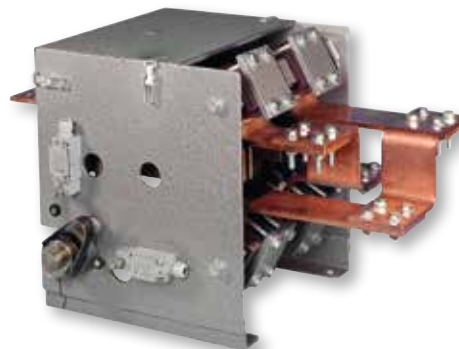

Reversing pole switch 2000 A, motor operated

Part-No. Reversing switch, 2-pole	Part-No. Reversing pole switch, 2-pole	Part-No. Reversing pole switch with timer	max. current load
52340	52520	52610	1000 A
52345	52525	52615	2000 A
52350	52530	52620	3000 A
52355	52535	52625	4000 A
52360	52540	52630	5000 A
52365	52545	52635	6000 A
52370	52550	52640	7000 A
52375	52555	52645	8000 A
52380	52560	52650	9000 A
52385	52565	52655	10000 A

Dimensions/installation dimensions are available on request.

Manufacture of complete product carriers

In addition to our contact systems, we also manufacture complete product carriers with and without crane/transport fixtures, both as spare parts for existing systems as well as designs for new systems. Versions with different crane/transport fixtures are available as castings or e.g. stainless steel welded constructions.

We have an extensive range of machinery for nonferrous metal processing with varying degrees of automation, which makes it possible to produce both individual parts and small series as well as larger series for new plants at low cost. We would be pleased to advise you on your applications.



Product carriers made out of aluminium and E-copper contact swords/assembly units

We also supply complete aluminium and aluminium alloy product carriers for anodizing plants. As the surface of untreated aluminium oxidizes when exposed to air, an electrically non-conductive layer forms here, which has a negative effect on the transfer of current from the product carrier to the contact saddles.

Contact saddles also in anodizing plants, are mostly made of copper, so that when aluminium product carriers are used, copper contacts aluminium. According to the electrochemical voltage series however, this can lead to corrosion if wetting by liquids such as water, electrolytes and acids takes place.

We therefore recommend equipping the contact points of aluminium product carriers with E-copper swords or E-copper plates. We also manufacture contact swords or contact plates made out of E-copper material for retrofitting the existing product carriers. The fixing of the copper parts to the aluminium product carriers should be done by means of bimetallic plates according to catalogue page 75. We can supply complete assembly units including all copper components, bimetallic sheets and stainless steel screw material, so that an uncomplicated and quick assembly can be carried out on site.



Manufacture and construction of busbar systems, busbar components and mounting accessories

Range of services

- Automated punched copper or aluminium busbars up to a dimension of 200 x 15 mm
- Bent and punched copper and aluminium busbars up to a dimension of 200 x 20 mm
- Edged large busbars in a width > 200 mm up to ca. 1000 mm and in strengths up to 35 mm
- Busbars out of copper bent over the high edge
- Torsion bent copper bars up to a width of 100 mm and a thickness of 10 mm
- Welded or soldered components
- Production of both individual spare parts as well as series production on machines with varying degrees of automation
- Constructional support for the design and dimensioning of power transmission components

Busbar systems

We design and manufacture busbar systems made of copper and aluminium bars individually adapted to the respective application. Whether for new constructions, conversions or extensions of older plants, we supply complete systems including busbar supports, flexible connections and even the complete screw- and installation material.

Even currents of several thousands amperes with correspondingly large busbar cross-sections are no problem for us. The design is carried out on CAD-systems and the subsequent production on modern machines with varying degrees of automation.

If the corresponding 3D-data are available, 90-95 % of the busbar system can be prefabricated in our company and delivered directly to the construction site with all the necessary installation accessories. This considerably shortens necessary assembly times on site, which can reduce costs, especially since the production of components in the factory is much cheaper than machining them on site.

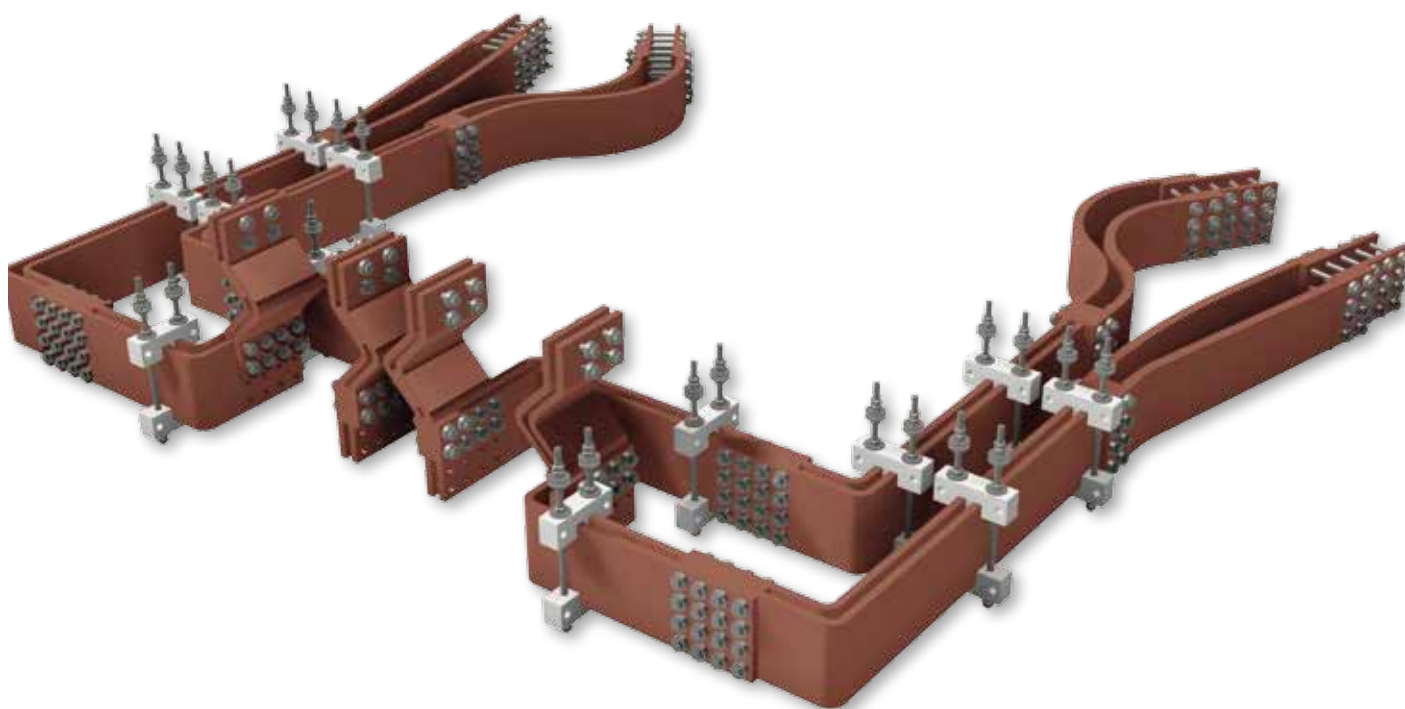

Detailed information about our possibilities are available in our catalogue no. 4 "Busbars, non-ferrous metal working and accessories". We will gladly send you this catalogue on request.

druseidt contacts for plating racks

Different systems. Simply, robust and flexible to use

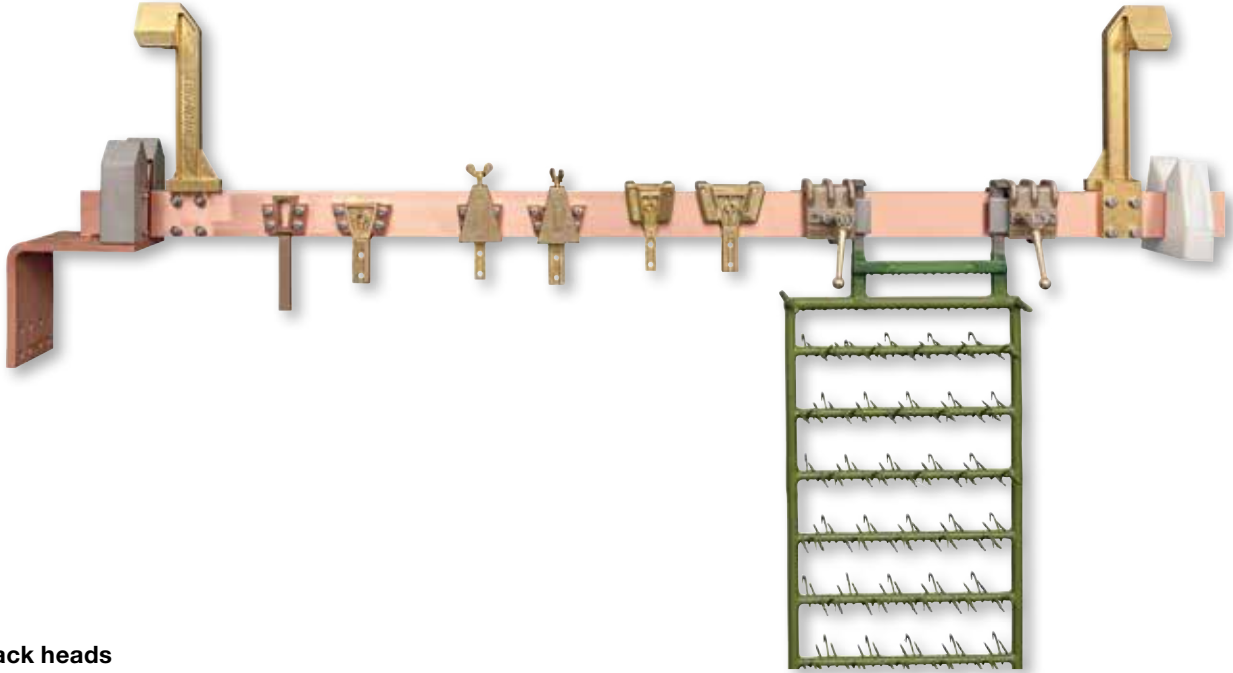

Contact rack heads

Contact rack heads in dovetail shape for screwing/soldering on. In conjunction with our free-sliding contact holders **Part-No. 31901 and 31902** or the screw-on holders, **Part-No. 51540/41** they offer a good and inexpensive way to contact galvanizing racks.

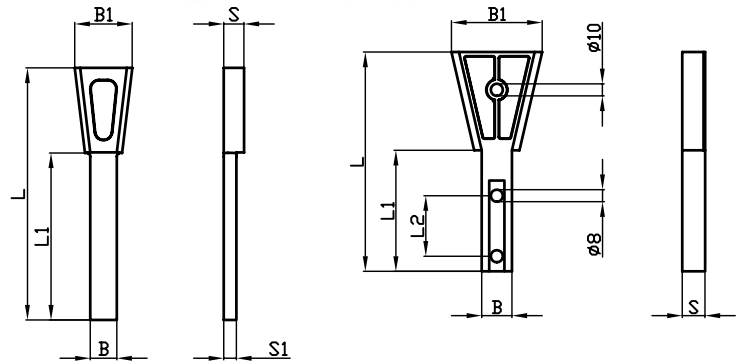

Part-No.	Technical data								weight kg/pcs.
	current load	dimensions mm							
51520	500 A	L	L ₁	L ₂	B	B ₁	S	S ₁	0,45
51521	500 A	135	70	35	19	45	15	-	0,35
51537	1200 A	135	70	35	30	65	15	-	0,50

Contact holders

These contact holders are used to hold our contact rack heads **Part-No. 51520/21 and 51537** or products of the same dimensions. They are infinitely adjustable for product carriers from 5-20 mm thickness. The contact holders can be freely moved on the product carrier and are locked by means of a sturdy brass wing screw. druseidt contact holders are made of a high-quality cast alloy that reliably prevents bending up also when working with heavier product carriers.

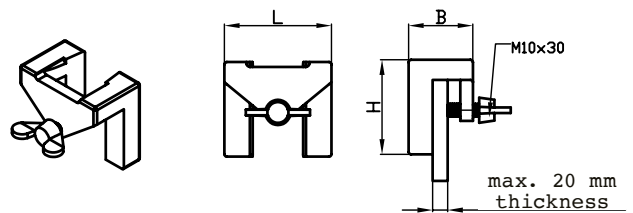

Part-No.	Technical data				weight kg/pcs.
	suitable for rack head	dimensions mm			
31901	51537	L	B	H	1,10
31902	51520/21	85	51	70	0,85

Contact holders for contact rack heads

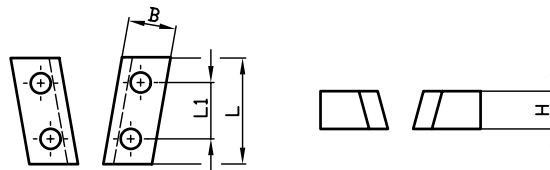

Part-No.	Technical data					
	dimensions mm					
	L	L1	B	H	drilling- Ø	weight kg/pcs.
51540	50	25	19	15	8,5	1,10
51541	56	25	18	15	8,5	0,85

Note: Part-No. 51540 suitable for working with rack heads Part-No. 51520/21.
 Part-No. 51541 suitable for working with rack heads Part-No. 51537.
 The fastening is done by screwing it onto the product carrier.

Safety clamp for contact holders Part-No. 51540/51541

With relatively light galvanizing racks, there is always the problem that buoyancy in the bath can cause problems with contacting/current transfer to the product carriers. Today's modern plants are also equipped with transport-systems for the racks, which increase cycle times and productivity through high acceleration. Unsecured light racks, e.g. in the area of plastic electroplating, can unhinge here and rack falls can occur in the plating baths. The druseidt safety clamp was developed to avoid these problems and to optimize the current transfer between the product carrier and the rack.

It is dimensionally designed in such a way that it can be used in conjunction with our rack heads Part-No. 51520/51521/51537 when our holders Part-No. 51540/41 are used. The safety clamp is placed over the copper holders and the suspended rack head and locked and tightened with a wing screw. In this way, the rack head is pressed against the product carrier with great pressure and unhooking is prevented both during the rack transport and by buoyancy in the bath. In addition the high contact pressure optimizes the current transfer between galvanizing rack and product carrier.



Safety clamp **Part-No. 31903**
 Material: Brass
 weight: kg/pcs 0,61 kg

Eccentric clamping rack heads

Freely moveable contact rack heads suitable both as a contact element for plating racks and as a terminal contact at the end of cable connections.

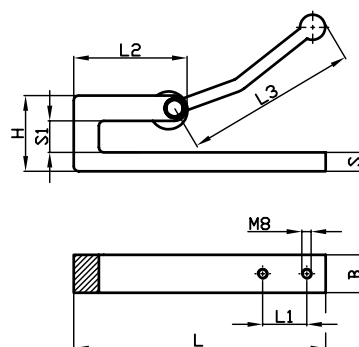

The clamping is effected by an eccentric lever. The rack heads are supplied adjusted to the product carrier/busbar thickness. **Therefore when placing an order please specify the thickness of the product carrier/busbar.**

Part-No.	Technical data										
	max. current load	suitable for busbar thickness	dimensions mm								weight kg/pcs.
L			L ₁	L ₂	L ₃	B	H	S	S ₁		
51635	500 A	10/15	135	30	58	125	26	44	10	19	0,70
51640	800 A	10/15	200	35	90	145	30	50	11	18	1,20
51641	1000 A	20	200	35	90	145	30	59	14	24	1,50

druseidt quick release clamps for clamping plating racks and anodes

These quick release clamps developed by druseidt enable extremely fast and contact safe clamping of plating racks or anodes. By simply actuating the clamping lever (approx. $\frac{1}{4}$ - $\frac{1}{2}$ turn) the rack is pressed against the product carrier with great pressure. The force is transmitted by means of a clamping lever via a stainless steel pressure plate to the rack and the product carrier. The high contact pressure on the product carrier prevents buoyancy even when using extremely light plating racks and ensures optimum current transmission.

When using this druseidt contact system, machining of the plating racks in the contact area becomes unnecessary. Whether square, rectangular, round or hexagonal profile shapes, the druseidt quick release clamp clamps them quick and securely. Racks with contact heads already screwed on can also be clamped without any problems. Only as many contact clamps as fit on the product carrier are needed to clamp the racks.

Compared to the total costs of using conventional systems (costs for machining the racks + number of the contact heads/clamping devices + possible machining of the product carriers) this contact system offers a favourable alternative in terms of price, especially for companies with a large number of racks.

The quick release clamps are placed on the product carriers from above and can then be moved freely along the product carrier. Locking on the product carrier is done by means of a stainless steel clamping screw. An additional stainless steel safety clip prevents the contact clamps from falling into the bath during the loading and unloading process. druseidt quick release clamps are made of a special acid-resistance alloy.

The mechanical strength is matched to the high clamping forces that occur. All springs, screws, pressure plates and fastening material are made of stainless steel. The spring loaded clamping lever is also made of a special acid-resistant alloy and can be adjusted in any position after the clamping process is finished, so that it does not interfere with the coating process or rack transport. Our quick release clamps are supplied adjusted to the dimensions of the product carrier and to the width and thickness of the plating racks in the area to be clamped.

Various sizes with different clamping ranges are available, so that this system can be used with almost all common designs of plating racks and product carriers. In general it is possible to clamp the racks on the left, right or both sides.

A centrally tensioned version is also available for small racks. **When ordering, please indicate clamping range/Part-No./product carrier thickness and height as well as rack thickness and width in the area to be clamped.**

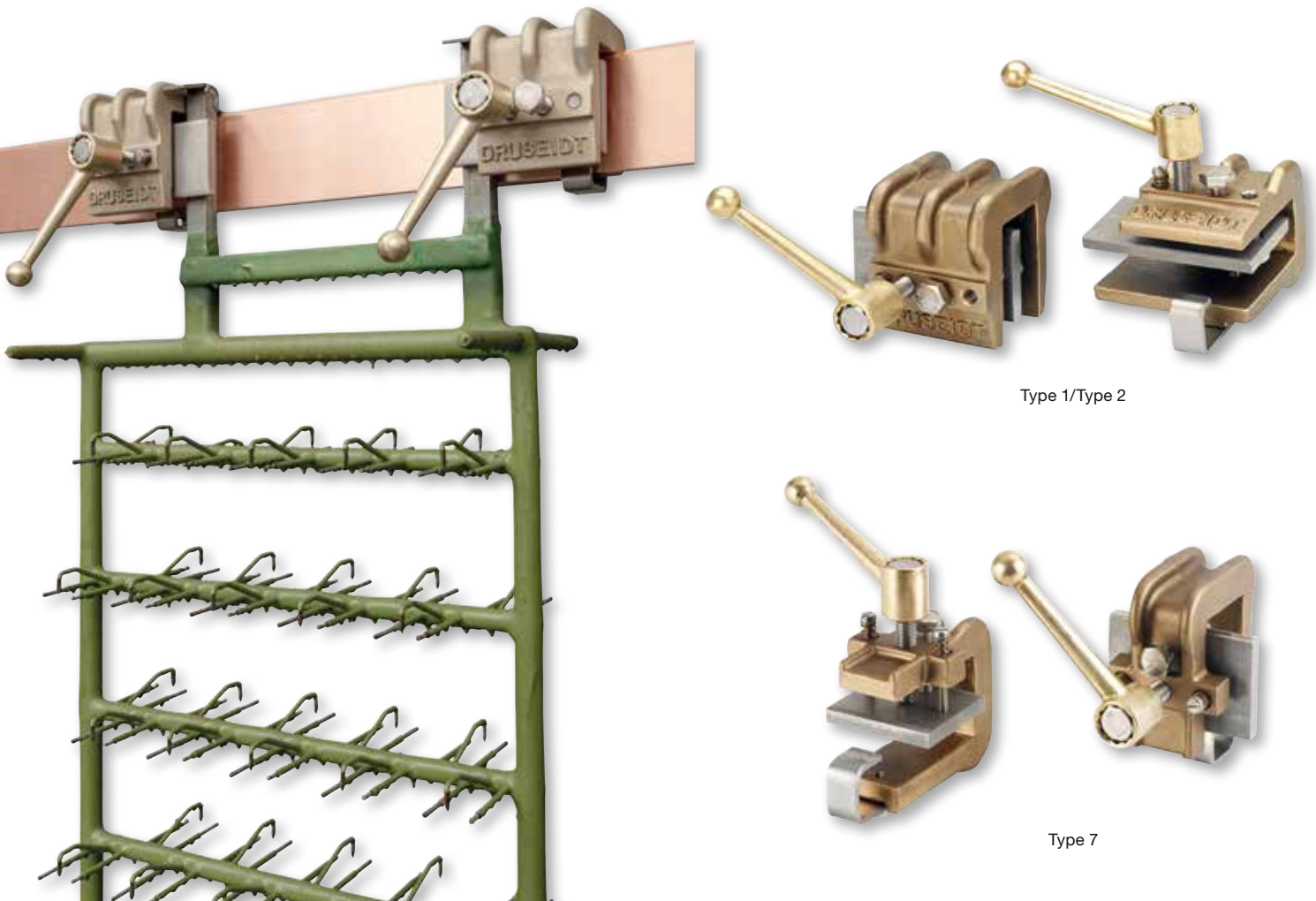

Type 1/Type 2

Type 7

druseidt quick release clamps
for clamping plating racks and anodes

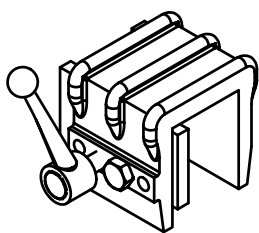

Type 1 - 2

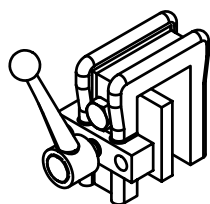
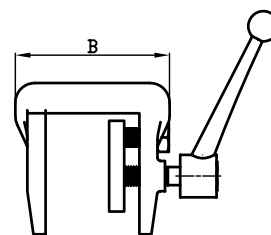
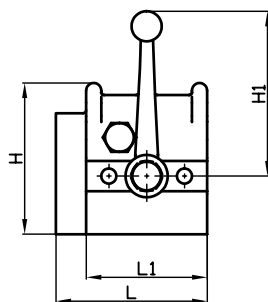

Type 7

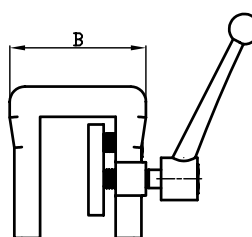
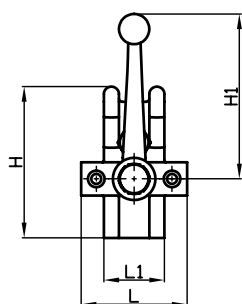

Part-No.	Technical data							
	design	max. clamping range	dimensions mm					weight kg/pcs.
			L	L ₁	B	H	H ₁	
31950	Type 1 clamping left	30	100	80	85	105	115	2,80
31951	Type 1 clamping right							2,80
31952	Type 1 clamping both sides							2,90
31955	Type 2 clamping left	50	100	80	105	105	115	3,10
31956	Type 2 clamping right							3,10
31957	Type 2 clamping both sides							3,20
Narrow design for tight spaces								
31980	Type 7 clamping left	35	70	40	95	105	115	1,80
31981	Type 7 clamping right							1,80
31982	Type 7 clamping both sides							1,90
31983	Type 7 clamping centric							1,70

Note: The clamping range is determined by adding the product carrier thickness and the rack thickness in the area to be clamped. Furthermore, the quick release clamp is equipped with a stainless steel safety clip according to the height and thickness of the product carrier.

The width of the stainless steel clamping plates projecting to the right/left or on both sides is adjusted to the rack width and is normally 25 mm. **Therefore when ordering please indicate clamping range/Part-No./ product carrier thickness and height as well as rack thickness and width in the area to be clamped.**

Clamping possibilities

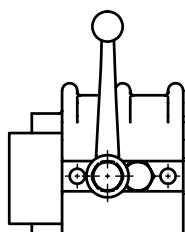

Clamping left

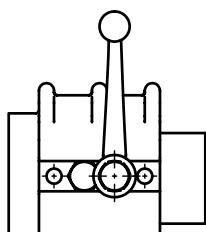

Clamping right

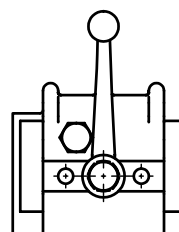

Clamping on both sides

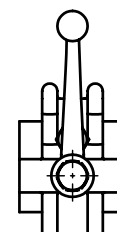

Clamping centric

Suspended galvanizing barrel units and replacement barrels

Suspended galvanizing barrel units

Material: Plexiglas (PL) or Polypropylene (PP)

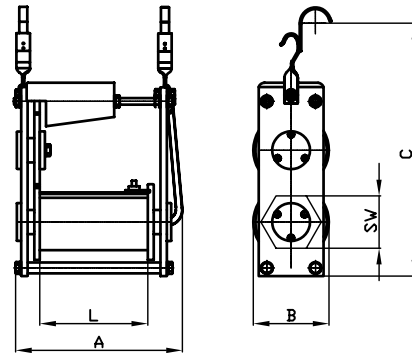

Part-No.		Technical data							
Type: PL	Type: PP	Fill quantity	dimensions mm					DC-Motor 6-12 V reversible	weight kg/pcs.
			L	SW	A	B	C		
34411 PL	34411 PP	1,5 kg	150	100	270	140	440	7,2 Nm	5,0
34412 PL	34412 PP	2,0 kg	200	100	320	140	440	7,2 Nm	5,5

Spare parts:

34000	DC replacement motor - reversible 6-12 V, 7,2 Nm
55058	Replacement contact cable with exchangeable contact bulb out of brass

Note: Suitable for small lots of small pieces. Galvanizing power is motor power as well. Barrel rotations 10 RPM. Standard barrels with profiled inner walls.
Possible perforations:
PL Ø from 1,0 mm / = from 0,5 mm, PP Ø from 1,0 mm / = from 0,5 mm.

The standard perforation that we deliver is Ø 2.0 mm.
If you require another perforation, please indicate this in the order.
Besides the standard version, 12 or 24 Volt DC motors are also available.

Suspended galvanizing barrel units

Material: Plexiglass (PL) or Polypropylen (PP)

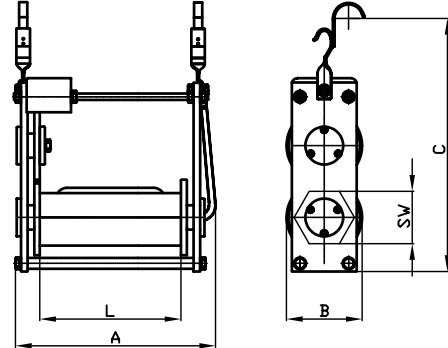

Part-No.		Technical data							
Type: PL	Type: PP	Fill quantity	dimensions mm					DC-Motor 6-12 V reversible	weight kg/pcs.
			L	SW	A	B	C		
34421 PL	34421 PP	6,0 kg	250	180	400	225	540	7,2 Nm	7,5
34422 PL	34422 PP	7,0 kg	300	180	450	225	540	7,2 Nm	8,0
34423 PL	34423 PP	9,0 kg	350	180	500	225	540	7,2 Nm	8,5
34424 PL	34424 PP	12,0 kg	450	180	600	225	540	7,2 Nm	8,8
34431 PL	34431 PP	7,0 kg	250	180	400	225	575	15,0 Nm	8,8
34432 PL	34432 PP	8,0 kg	300	180	450	225	575	15,0 Nm	9,0
34433 PL	34433 PP	10,0 kg	350	180	500	225	575	15,0 Nm	9,2
34434 PL	34434 PP	13,0 kg	450	180	600	225	575	15,0 Nm	9,7

Spare parts:

34000	DC-replacement motor - reversible 6-12 V / 7,2 Nm
34002	DC-replacement motor - reversible 6-12 V / 15 Nm
55060	Replacement contact cable with exchangeable contact bulb out of brass

Note: Suitable for small lots of small pieces. Galvanizing power is motor power as well. Standard barrels with profiled inner walls.
Possible perforations:
PL Ø from 1,0 mm / = from 0,5 mm, PP Ø from 1,0 mm / = from 0,5 mm.

The standard perforation that we deliver is Ø 2.0 mm.
If you require another perforation, please indicate this in the order.
Besides the standard version, 12 or 24 Volt DC motors are also available.

Suspended galvanizing barrel units and replacement barrels

Suspended galvanizing barrel units

Material: Polypropylen (PP)

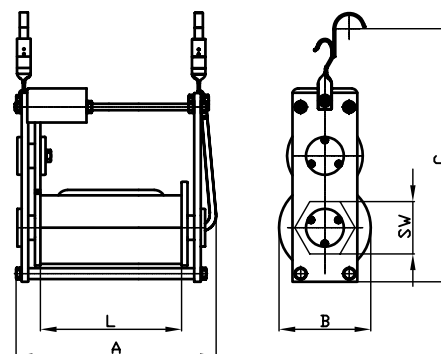

Part-No.	Technical data							
	Type: PP	Fill quantity	dimensions mm				DC-Motor 6-12 V reversible	weight kg/pcs.
		L	SW	A	B	C		
34440	1,5 kg	150	100	270	140	440	7,2 Nm	5,0
34441	2,0 kg	200	100	320	140	440	7,2 Nm	5,5
34442	6,0 kg	250	145	400	180	515	7,2 Nm	7,0
34443	7,0 kg	300	145	450	180	515	7,2 Nm	8,0
34444	7,0 kg	250	180	400	225	540	7,2 Nm	7,8
34445	8,0 kg	300	180	450	225	540	7,2 Nm	8,0
34446	10,0 kg	350	180	500	225	540	7,2 Nm	8,6
34447	13,0 kg	450	180	600	225	540	7,2 Nm	9,2
34448	9,0 kg	250	180	400	225	575	15,0 Nm	9,1
34449	10,0 kg	300	180	450	225	575	15,0 Nm	9,3
34450	12,0 kg	350	180	500	225	575	15,0 Nm	9,5
34451	14,5 kg	450	180	600	225	575	15,0 Nm	10,0
34452	12,0 kg	250	200	400	245	575	15,0 Nm	9,8
34453	13,0 kg	300	200	450	245	575	15,0 Nm	10,8
34454	15,0 kg	350	200	500	245	575	15,0 Nm	11,7
34455	16,0 kg	450	200	600	245	575	15,0 Nm	12,3

Spare parts:

- 34000 DC-replacement motor reversible 6-12 V, 7,2 Nm
- 34002 DC-replacement motor reversible 6-12 V, 15 Nm
- 55060 Replacement contact cable with exchangeable contact bulb out of brass

Note: This is suitable for galvanizing small parts on a mass basis. Versions with wider lid openings formed sealing covers. The power used for galvanizing is the motor power as well.

Possible perforations: \varnothing 1,0 mm/ = 0,5 mm. **Standard perforation 2,0 mm.**

If different perforations are required, please indicate your requirements in the order. If desired, 12 and 24 Volt DC motors or versions with perforation blocks \varnothing 20 mm (Perforation / = 0,2 mm/□ 0,4/0,8 or 1,0 mm) for improved throughput are also available.



Replacement barrels

Material: PP or PE 500

for galvanizing, pickling and phosphating

We supply replacement barrels made of different materials in lengths up to 1200 mm and wrench sizes up to 400 mm according to customer's requirements, samples or drawings. All barrels can be also configured for already existing barrel units.

Other dimensions and designs of suspended barrel units on request.

Sealed contact cables for electroplating barrels

druseidt system, with solderless pressed contact bulbs 70-120 mm²
resp. exchangeable brass bulbs 25 mm²

Long-life absolutely liquid-tight contact cables with flexible special PVC-based hose. The contact bulbs are pressed liquid tight with both the flexible insulated inner conductor and the special outer hose. With this manufacturing method, no additional sealing parts or hose clamps are needed any more.

Therefore, snagging of parts to be coated on hose clamps or sealing elements is no longer possible. The risk of breakage is minimized and the service life of the cables is extended. For galvanic barrels with small axle bushings, we manufacture contact cables in welded double hose design.

We also manufacture contact cables with heat resistant insulation for applications under elevated temperatures, drum dryers etc. on request. Contact cables with contact bulbs or connection elements according to customer requirements or in larger cross-sections (e.g. 150 mm²) are available too. We manufacture a wide range of special designs at short notice and at low costs.

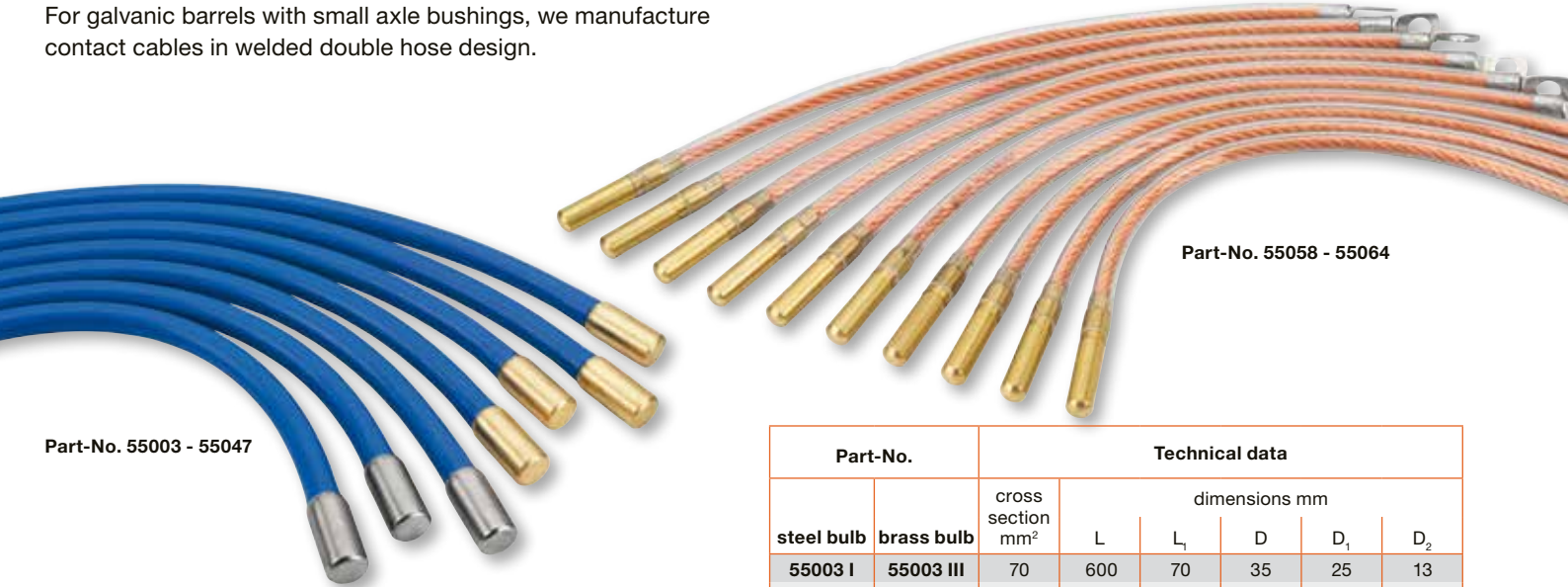

Part-No. 55003 - 55047

Part-No. 55058 - 55064

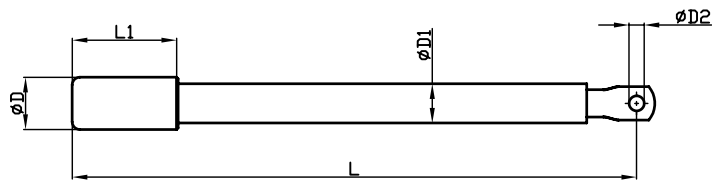

Standard design

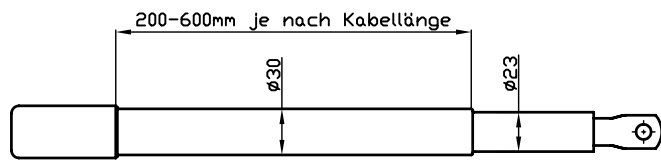

Special design in welded double hose design
200-600 mm depending on the cable length

Part-No.		Technical data					
steel bulb	brass bulb	cross section mm ²	dimensions mm				
			L	L ₁	D	D ₁	D ₂
55003 I	55003 III	70	600	70	35	25	13
55004 I	55004 III		700				
55005 I	55005 III		800				
55006 I	55006 III		900				
55007 I	55007 III		1000				
55008 I	55008 III		1100				
55009 I	55009 III		1200				
55010 I	55010 III		1300				
55023 I	55023 III	95	600	70	35	29	13
55024 I	55024 III		700				
55025 I	55025 III		800				
55026 I	55026 III		900				
55027 I	55027 III		1000				
55028 I	55028 III		1100				
55029 I	55029 III		1200				
55030 I	55030 III		1300				
55040 I	55040 III	120	600	70	35	30	13
55041 I	55041 III		700				
55042 I	55042 III		800				
55043 I	55043 III		900				
55044 I	55044 III		1000				
55045 I	55045 III		1100				
55046 I	55046 III		1200				
55047 I	55047 III		1300				

Contact cables for suspended barrel units 6/12 V

with transparently PVC-hose and exchangeable brass bulb

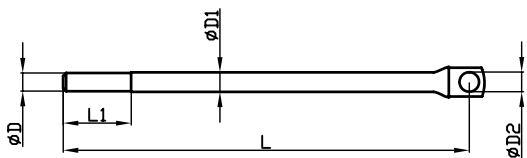

Part-No.		Technical data					
brass bulb	cross section mm ²	dimensions mm					
		L	L ₁	D	D ₁	D ₂	
55058	25	420	45	15	13	13	
55060		540					
55062		600					
55064		900					

Note: Other lengths or other bulb materials e.g. steel/stainless steel or others on request.

Contact saddles 1500 A for round bolts 40-70 mm Ø

Half-ball bearing contact saddles with moveable spring loaded, nub like embossed contact surfaces. The contact surfaces and foils are made of E-Copper and the supporting base body is made of red brass. Suitable for contacting round bolts with 40-70 mm Ø.

As standard, the contact saddle is supplied in two loose halves. On request, mounted contact saddles adjusted to the existing round contact screwed onto an E-Copper busbar, optionally with or without insulating plate, are also available.



Part-No. 51295
2-part standard design



Special design:
on E-copper busbar mounted contact unit
with insulating plate

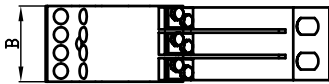
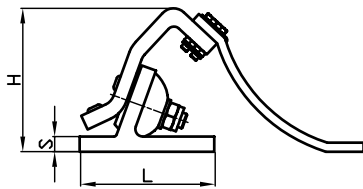

Part-No.	Technical data					
	max. current load	dimensions mm				weight kg/ one contact pair
L		B	H	S		
51295	1500 A	90	50	100	10	13

Support saddles for round bolts 20-60 mm Ø



Part-No. 51150 / 51155



Part-No. 51161

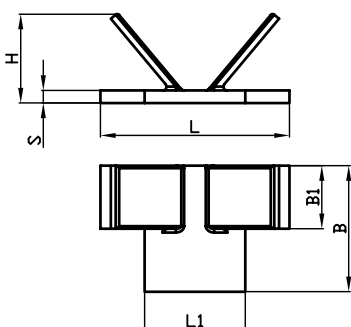

Part-No.	Technical data							
	max. current load	dimensions mm						weight kg/pcs.
L		L ₁	B	B ₁	H	S		
51150	300 A	160	60	105	50	75	8	2,00
51155	300 A	160	-	-	50	75	8	1,70
51161	-	160	-	-	50	75	8	1,10

Note: 51150/55 = Stable current carrying contacts with or without connection lugs. Standard design undrilled. **Part-No. 51161** = Non-current-carrying support saddles made out of plastic PE 500. Standard design drilled with slotted hole 12 x 24 mm on both sides.

Contactors for electroplating barrel units



Contactors for the transmission of the motor current inside of electroplating barrel units. Standard version not touch protected each consisting of upper and lower part, Part-No. 51205 = 3 spring loaded round contacts matched to lower part 51200.

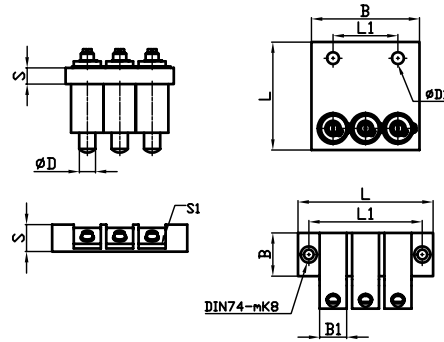

Part-No. 51205
upper part

Part-No. 51200
lower part

Part-No.	description	Technical data								weight kg/Stck.
		dimensions mm								
		L	L ₁	B	B ₁	S	S ₁	D	D ₁	
51200	lower part	125	105	40	25	25	5	-	-	0,40
51205	upper part	100	60	100	15	15	-	15	11	0,60

Contactors according to customer requirements



In addition to the 3-pole standard design, Part-No. 51200/51205 we also manufacture designs according to customer requirements with other number of poles, e.g. 4-pole or other dimensions for the lower parts. The spring loaded round contacts from the Part-No. 51205 are also available individually and on request, with surface finish (tin-plated, nickel-plated, silver- or gold-plated).

Touch-protected contactors for electroplating barrel units



3-pole contacting for transmission of the motor current inside of electroplating barrel units. The lower part is designed to be touch-protected in the contact area (protection class IP 20/ finger-safe). The cable connections are also protected mounted in the housings of the upper/lower-part. The contacting can therefore also be used for 42 V motors. On request both the top and bottom parts can be provided with fixing brackets according to customers specification.

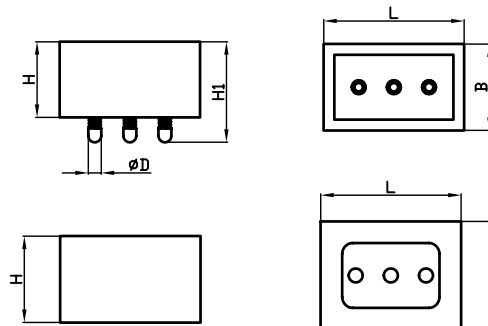

Part-No. 51218
upper part

Part-No. 51217
lower part

Part-No.	description	Technical data					weight kg/Stck.
		dimensions mm					
		L	B	H	H ₁	D	
51217	lower part	130	100	80	-	-	1,50
51218	upper part	130	80	30	70	12	1,00

Contact systems for rotating collectors

High-current carbon brushes with holders

High current carbon brushes in conjunction with the appropriate holders are current transmission elements that continuously transmit electric currents, preferably to rotating current collectors as rollers, round contacts or shafts. The dimensioning of the high-current carbon brushes and the design of the holders are adapted to the respective application and delivered in accordance with the system and installation situation.

The standard versions contained in this catalogue cover a wide range of possible applications. In addition, we design and manufacture complete, ready-to-install busbar systems with all accessories, e.g. for electroplating plants or sheet metal finishing plants such as strip galvanizing or similar applications. For detailed technical information on this product range, please refer to catalogue page 53 or our catalogue no. 4 "Busbars, non-ferrous metal working and accessories", which we will be pleased to send you free of charge on request.

Main areas of application

- Within the electrolytic coating of strips, sheets or wires (e.g. strip galvanization in rolling mills)
- Within electroplating plants (e.g. copper plating of gravure cylinders, chrome plating of rollers etc.)
- Within other systems where higher currents have to be transmitted to moving components (e.g. mechanical engineering plants, welding plants, wire annealing plants, wind power plants etc.)

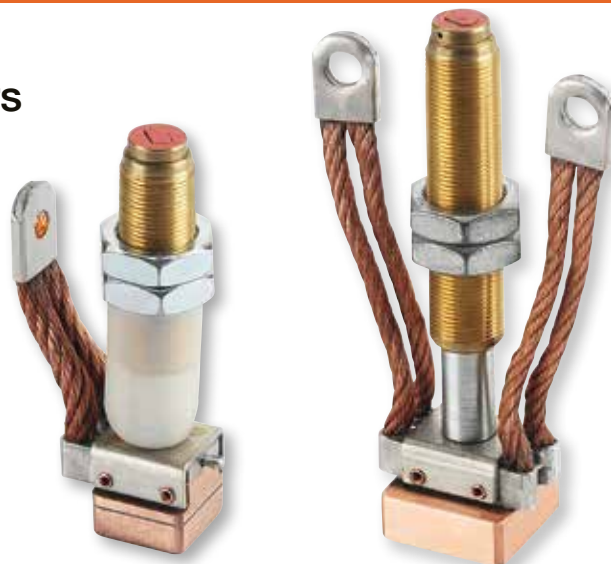

Dimensioning of high current carbon brushes

Due to the wide variety of applications and areas of use of high current carbon brushes, it is necessary to adapt the respective design to the individual application. Therefore, the best possible design and dimensioning depends for example, on the installation situation, the heat dissipation possibility, the ambient and operating temperature of the carbon brushes, the general ambient conditions as the degree of contamination, the speed of rotation, the number of carbon brushes used per contact point and the material to which the current is to be transmitted from the high current carbon brushes.

The running surfaces of the carbon brushes should be optimally designed to keep voltage drops as low as possible, especially in the low-voltage range, and to ensure good heat dissipation. It may therefore make sense to equip a contact point with several small carbon brushes instead of a large one. For example, in the case of excessive heat generation or transmission of thermal pre-loaded elements, the running surface cross-section should also be oversized by approx. 25 %. If several high current carbon brushes used in parallel, the current load per carbon brush should be reduced by 10-15 %. Maximum possible current loads of high current carbon-brushes should only be run with slow running current collectors. For power transmission to immovable current collectors, please consult us. We will be happy to advise you on your applications.

Technical data

druseidt-high-current carbon brushes quality druso 21 and druso 31

	druso 21	druso 31
Material	copper graphite/leaded	copper graphite/lead-free
Specific resistance	0,1 $\Omega \cdot \text{mm}^2/\text{m}$	0,08 $\Omega \cdot \text{mm}^2/\text{m}$
Metal content	90 %	75 %
Flexural strength	max. 30 N/mm ²	max. 90 N/mm ²
Rockwell hardness HR 10/40	50	108
Volume weight	5,5 g/cm ³	4,9 g/cm ³
Current density max.	40 A/cm ²	28 A/cm ²
Peripheral speed	25 m/S	30 m/S
Contact voltage drop	< 1,3 V	< 1,3 V
Friction efficient	0,09-0,18	0,09-0,18

Material data acc. to DIN IEC 413 for new carbon brushes. Since scattering is possible, they do not represent guaranteed properties in the legal sense.

High current carbon brushes

suitable for mounting in linear adjustable telescopic holders

Special material qualities are required to ensure the lowest possible loss of current transmission. The standard qualities we use are produced as a plate in a special pressing process and then machined. They can be supplied in both leaded and lead-free quality. Both versions are characterized by a high metal content and consequently high possible current densities of up to 40 A/cm² resp. 28 A/cm².

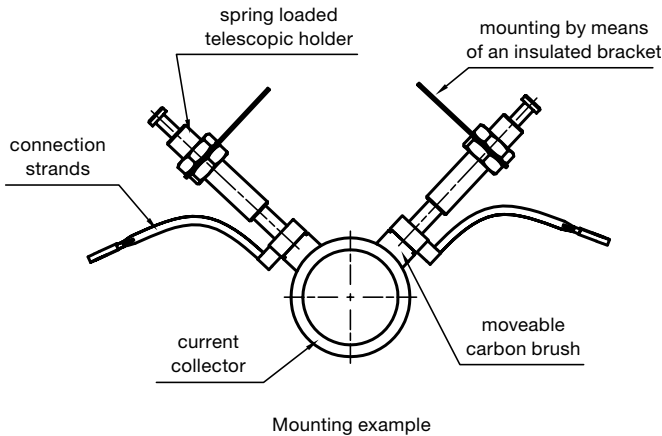

When using current transmission systems with telescopic holders, the high-current carbon brushes are suspended in a free moving manner and can therefore adapt well to the current roller, slip ring or contact strip. The contact pressure is transmitted by a pressure spring in the holder.

The design of the carbon brushes is either with or without radius adapted to the intended use and supplied according to customer requirements. The telescopic holders can be mounted in a space saving way and offer a wide range of options. If possible, the telescope holders should be attached via an insulated bracket. The current should only be conducted via the stranded cables to avoid erosion in the holders. The diameter of the mounting hole for all listed holders is 22 mm. By means of the two nuts supplied, the current transmission system can then be linearly adjusted to the appropriate position and installed.

Telescopic holders with either 50 N or 100 N spring forces are available. As contact pressure for the high-current carbon brushes we recommend a value of 2,5-4 N/cm² running surface. When selecting the spring force, the carbon cross-section and the circumferential speed must be taken into account. With pleasure we advise you on your applications.

Part-No. 35000/35060

Part-No. 35004/35064

Part-No. 35007/35067

Part-No. 35011/35070

Part-No. 35001/35061

Part-No. 35005/35065

Part-No. 35009/35069



Part-No.				Technical data/dimensions mm					
leaded quality druso 21	possible current load	lead-free quality druso 31	possible current load	carbon brush dimensions w x d x h	height with rivet fitting	connection strands cross-section mm ²	flexible length	connection pieces number	drilling-Ø
35000	280 A	35060	230 A	30 x 30 x 23	30	2 x 25	98	1 x 20 x 26	10,5
35001	280 A	35061	230 A	30 x 30 x 23	30	2 x 25	175	1 x 20 x 26	10,5
35004	300 A	35064	300 A	30 x 45 x 35	41	2 x 25	95	1 x 20 x 26	10,5
35005	450 A	35065	400 A	38 x 40 x 23	30	4 x 16	98	2 x 20 x 26	10,5
35007	500 A	35067	400 A	38 x 40 x 23	30	4 x 25	170	2 x 20 x 26	10,5
35009	520 A	35069	420 A	40 x 40 x 38	35	4 x 25	98	2 x 20 x 26	10,5
35011	550 A	35070	450 A	70 x 30 x 40	46	4 x 25	98	2 x 20 x 26	10,5

Note: All versions with rivet fitting. Connection strands with bare copper wires and tinned connection pieces. Tinned wired or other drilling on request. Carbon brushes rectangular without radius. **When ordering, please indicate any desired radii and the direction (enclose sketch if possible).** The possible current load indicated in the tables is given taking into account the cross-sections of the connection strands.

When selecting/dimensioning, however, it is essential too, to take into account our instructions on catalogue page 63 or to consult us. For linear movement on longer conductor rails (e.g. in the area of KTL-systems) the carbon brushes can be provided with the necessary run-up radii on request.

Linear adjustable telescopic holders for high current carbon brushes

Material: Brass/Steel zinc plated



Part-No. 35016



Part-No. 35018



Part-No. 35022/35028

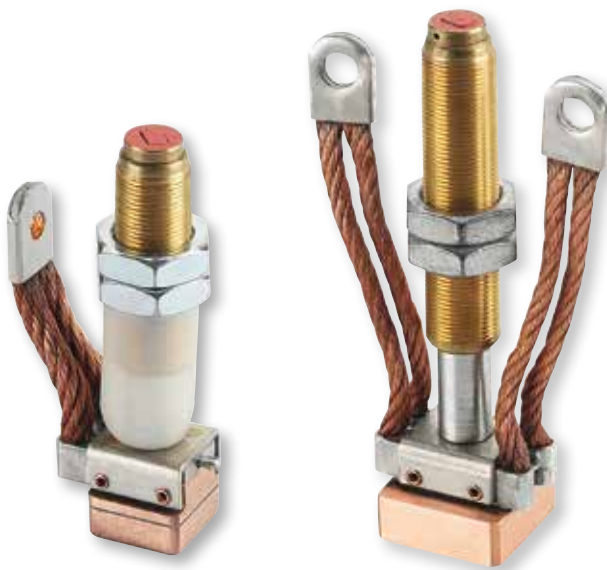

High current carbon brushes with mounted telescopic holders

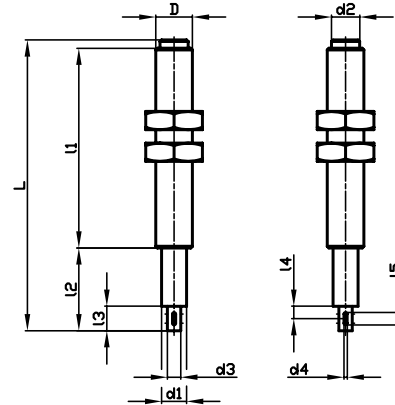

Part-No.	Technical data												
	contact pressure	stroke	dimensions mm										
			L	L ₁	L ₂	L ₃	L ₄	L ₅	D ₁	D ₂	D ₃	D ₄	D
35016	50 N	15	80	49	25	10	4	4,2	16	17	7,5	4,2	M 22 x 1,5
35018	50 N	23	107	67	36	12	6	4,2	16	17	7,5	4,2	M 22 x 1,5
35020	50 N	20	118	85	28	10	4	4,2	16	17	7,5	4,2	M 22 x 1,5
35022	50 N	30	143	95	44	10	4	4,2	16	17	7,5	4,2	M 22 x 1,5
35028	100 N	30	143	95	44	10	4	4,2	16	17	7,5	4,2	M 22 x 1,5

Note: Best.-Nr. 35016 small compact design for installation in confined spaces. All versions suitable for our high current carbon brushes acc. to catalogue page 64 with brush bore 8 mm. Other designs or materials on request.
 Part-No. 35018 can only be mounted with additional protective cap.

High current carbon brushes

suitable for mounting in pocket shaped holders

While the high current carbon brushes are freely suspended when telescopic holders are used, they remain in the pocket, provided for them when pocket shaped holders are used. This prevents the carbon brushes from tipping and the carbon brushes are centered accordingly. To ensure permanent monitoring of carbon brush wear in daily operation, we also offer some dimensions with an additionally glued-in so-called signal strand as standard.

The signal contact is made from the slip ring/high current carbon brush to the copper signal wire. This signal can then be forwarded for evaluation. This space-saving monitoring option provides additional safety in the operation of the power transmission system. On request we can also offer you other dimensions with signal strands.



Part-No.				Technical data/dimensions mm				
leaded quality druso 21	possible current load	lead-free quality druso 31	possible current load	carbon brush dimensions w x d x h	signal strand	connection strands		connection bore-Ø
						cross-section mm ²	wire surface	
35080	55 A	35090	55 A	20 x 10 x 32	-	2 x 2,5	uncoated	5,5
35081	75 A	35091	75 A	25 x 12,5 x 32	-	2 x 4	uncoated	6,5
35082	75 A	35092	75 A	25 x 12,5 x 32	-	2 x 4/isol.	tinned	-
35083	230 A	35093	225 A	40 x 20 x 40	-	2 x 16	uncoated	8,5
35084	230 A	35094	225 A	40 x 20 x 40	-	2 x 16	uncoated	10,4
35085	230 A	35095	225 A	40 x 20 x 40	yes	2 x 16	uncoated	10,4
35086	230 A	35096	225 A	40 x 20 x 50	yes	2 x 16	uncoated	10,4
35087	410 A	35097	360 A	40 x 32 x 50	-	4 x 16	uncoated	10,4
35088	410 A	35098	360 A	40 x 32 x 50	yes	4 x 16	uncoated	10,4

Note: Part-No. 35082/35092 with insulated, tinned connection strands without connection pieces. All other versions with tinned connection pieces and uncoated stranded wires. Stranded tinned wires or other connection drillings on request. Carbon brushes rectangular without radius. **When ordering, please indicate any desired radii.**

The possible current load indicated in the table is given taking into account the cross-sections of the connecting strands. When selecting/dimensioning, however, it is essential too to take into account our instructions on catalogue page 63 or to consult us.

Pocket shaped holders for high current carbon brushes

Material: Brass



Part-No.	Technical data		
	description/design	Retaining bolt-Ø	suitable for high current carbon brush
35025	Double holder for carbon brush 20 x 10 mm	20 mm	35080/35090
35027	Double holder for carbon brush 25 x 12,5 mm	20 mm	35081-82 and 35091-92
35029	Double holder for carbon brush 40 x 20 mm	25 mm	35083-86 and 35093-96
35031	Double holder for carbon brush 40 x 32 mm	25 mm	35087-88 and 35097-98
35048	Single holder for carbon brush 40 x 20 mm	25 mm	35081-82 and 35091-92
35049	Single holder for carbon brush 40 x 32 mm / linear mounting		35087-88 and 35097-98
35057	Retaining bolt 20 mm Ø with thread M12, length 160 mm/100 mm isol.		
35058	Retaining bolt 25 mm Ø with thread M16, length 156 mm/124 mm isol.		

Note: The carbon brush holders **Part-No. 35025/27** are suitable for mounting on retaining bolt M12 **Part-No. 35057** and the carbon brush holders **Part-No.**

35029/31 and 35048 for mounting on retaining bolt M16 **Part-No. 35058**. The single holder **Part-No. 35049** is intended for linear mounting.

High current carbon brushes

suitable for mounting in combination holders

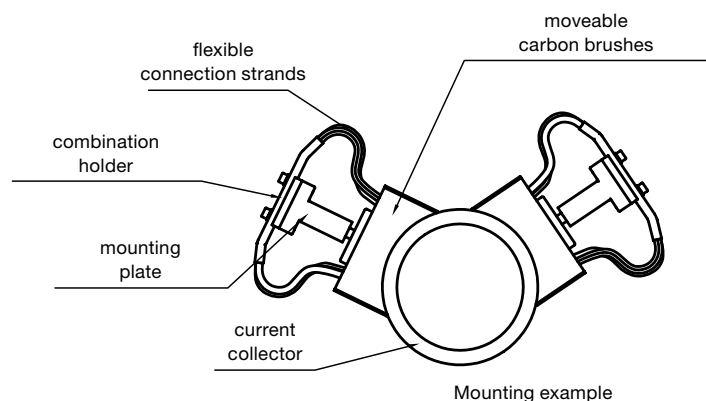

In conjunction with our combination holders, the high current carbon brushes are freely suspended and can thus adapt well to the current collector. The carbon brushes can be supplied either with or without radius according to the customer's requirements in both leaded (druso 21) or lead-free (druso 31) quality. The combination holders offered to match the carbon brushes are space-saving and can be used variably. Holders with 60 N to 150 N spring force are available. We recommend a carbon brush contact pressure of 2,5-4 N/cm² running surface, depending on the material quality, the carbon brush cross-section and the speed. With pleasure we'll advise you on your applications.



Part-No. 35034



Part-No. 35041



Part-No. 35045 with radius



Part-No. 35047 with radius

Part-No.				Technical data/dimensions mm				
leaded quality druso 21	possible current load	lead-free quality druso 31	possible current load	carbon brush dimensions w x d x h	connection strands cross-section mm ²	wire surface	connection pieces w x d x h	suitable combination holder
35034	600 A	35071	600 A	70 x 36 x 32	4 x 25	uncoated	2 x 60 x 9,8 x 6	35050/54
35035	600 A	35072	600 A	70 x 36 x 40	4 x 25	tinned	2 x 60 x 9,8 x 6	35050/54
35036	600 A	35073	600 A	70 x 36 x 45	4 x 25	tinned	2 x 60 x 9,8 x 6	35050/54
35037	500 A	35074	500 A	70 x 36 x 40	4 x 25/isol.	tinned	2 x 60 x 9,8 x 6	35050/54
35038	1100 A	35075	900 A	100 x 36 x 45	8 x 25	tinned	2 x 33 x 31 x 6	35055
35041	1200 A	35076	1100 A	118 x 40 x 60	10 x 25/isol.	tinned	1 x 100 x 31 x 8,5	35052/56
35043	1400 A	35077	1200 A	118 x 40 x 60	10 x 25	tinned	1 x 100 x 31 x 20	32052/56
35045	1400 A	35078	1200 A	118 x 40 x 60	10 x 25	tinned	1 x 100 x 31 x 8,5	32052/56
35047	1200 A	35079	1100 A	118 x 40 x 60	10 x 25/isol.	tinned	1 x 70 x 31 x 8,5	32056/56

Note: In the standard design all carbon brushes are rectangular without a radius. Therefore please indicate the desired radii when ordering. The specified possible current load is given taking into account the cross-sections of the connection strands.

When selecting/dimensioning, however, it is essential to take into account our instructions according to catalogue page 63 or to contact us. Other versions than indicated in the table as well as versions with signal wire on request.

Combination holders for high current carbon brushes

Material: Brass



Part-No.	Technical data		
	contact pressure	design	stroke
35050	60 N	casted	14 mm
35052	130 N	casted	14 mm
35054	60 N	milled	14 mm
35055	100 N	milled	14 mm
35056	150 N	milled	14 mm

Note: On request, all holders are also available with a protective cap.

Highly flexible copper connectors

Power leads in solderless crimped design

druseidt stranded connectors are extremely flexible components made out of flat or round strands with uncoated or tinned wires with a single wire-Ø 0,07 mm or 0,10 mm. Seamless contact sleeves are pressed onto the ends under high pressure without soldering, so that an extremely compacted connection surface is created. In this manufacturing process, materials of the same conductance (E-copper tube as well as stranded braids and cables made out of E-copper wires) are compacted together without the use of foreign materials such as solder or welding filler metals. This creates a flexible component with an extremely low electrical contact resistance. On request, all flexible power connectors can also be supplied insulated with PVC/silicone or other insulating hoses. For use in electroplating or anodizing plants we also supply splash proof sealed versions.

We also manufacture special designs according to samples, drawings or customer requirements at short notice and at a reasonable price. The specified current limiting values in the tables apply to individually installed (single laying) power connectors and are non-binding guide values. If several flexible power connectors are connected in parallel, a specific current carrying capacity reduction similar to that for busbars according to DIN 46371 must be taken into account.

When using insulated connections, the current carrying capacity is reduced by approx. 15-20 % of the table values.

Within electroplating or anodizing plants our highly flexible current connectors are ideally suited for connecting contact saddles, rectifiers or transformers to the busbar system as well as for realizing bath/contact saddle movements. We also supply ready assembled round stranded cable systems for applications in which rectifiers are not to be connected by means of rigid busbars, but rather flexibly.

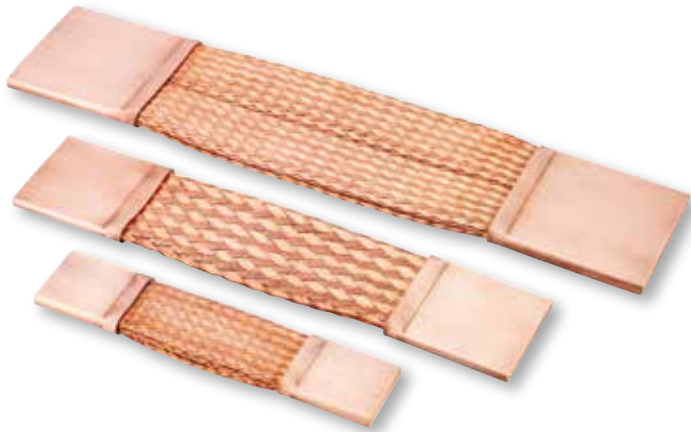

Highly flexible copper connectors without insulation



Highly flexible copper connectors with PVC-standard insulation

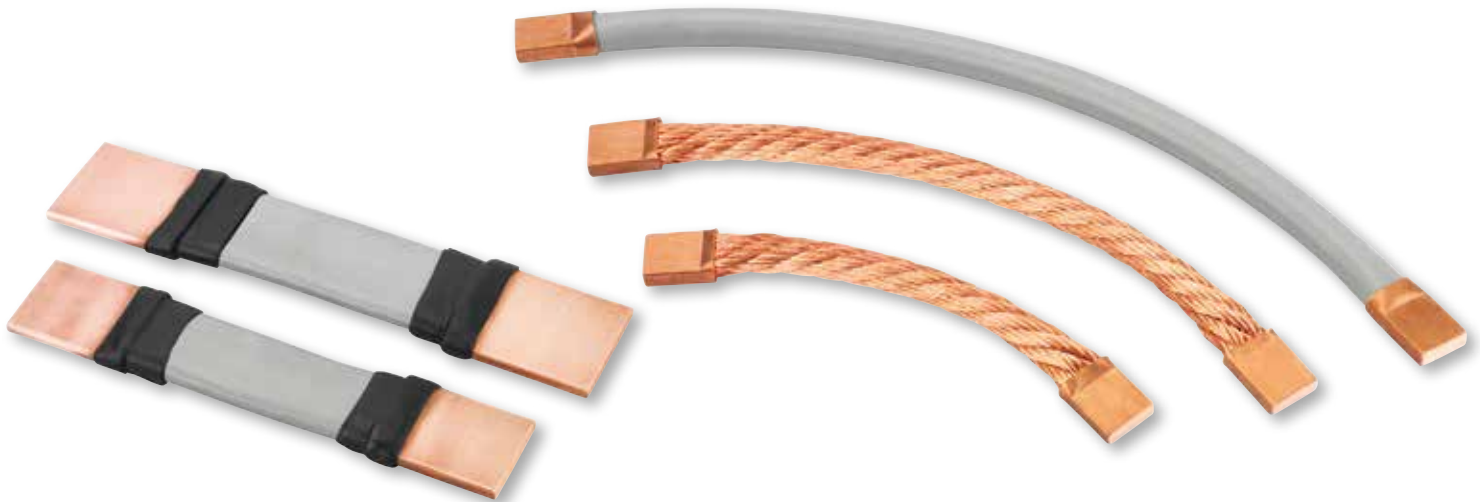

Highly flexible copper connectors PVC-insulated in splash proofed design

Highly flexible round stranded copper connectors with and without insulation

You will find detailed information about our extensive manufacturing possibilities for flexible and highly flexible power connectors in our catalogue No. 2 "Flexible air and water-cooled connectors and cables for Hi-Tech applications" which we will be happy to send you free of charge on request.

Highly flexible copper connectors in solderless pressed design 25-4500 mm²

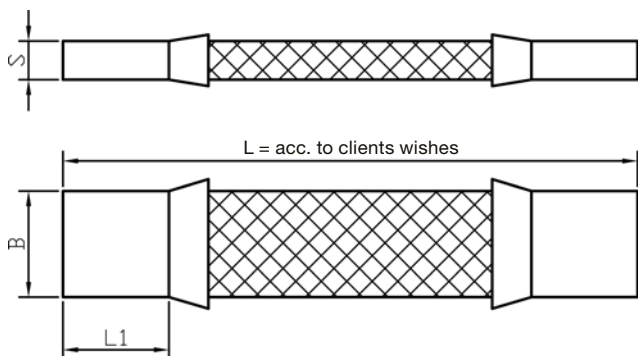

Technical data

Braids:

- made out of annealed Cu-ETP1-wires
- soft annealed
- uncoated surface is standard
- tinned surface on request
- wire-Ø 0,10 mm

Contact areas:

- seamless Cu-ETP-tube
- uncoated surface is standard
- tin-, nickel-, silver-coated surface on request

Insulation:

- PVC-hose (standard)
- Silicone-, glass-fibre-, shrinking tubes or others on request

Part-No.	Technical data						standard drilling patterns
	cross-section mm ²	dimensions mm			current-load Ampere		
		B	L ₁	ca. s	DC	AC	
02930	25	20	20	3,5	150	140	Type I
02931	50			5	250	240	
02932	75			7	350	340	
02933	100			8	400	380	
02934	25	25	25	3,5	150	140	
02935	50			4,5	300	280	
02936	75			6	350	340	
02937	100			7	450	420	
02938	125			8,5	500	470	
02939	50	30	30	4	300	290	
02940	75			5	400	390	
02941	100			6	450	440	
02942	150			8,5	550	540	
02943	200			11,5	650	640	
02944	300			15,5	800	790	
02945	100	40	40	7,5	500	480	
02946	150			7,5	600	590	
02947	200			9,5	700	680	
02948	250			11	800	780	
02949	300			13	900	850	
02950	400			15,5	1000	980	
02951	140	50	50	6	650	630	Type II
02952	210			8	800	780	
02953	280			10	950	900	
02954	420			14	1050	1000	
02955	560			16	1350	1200	
02956	140	60	60	6,5	700	680	
02957	210			8	900	850	
02958	350			11	1150	1100	
02959	490			13	1350	1300	
02960	560			15	1400	1350	
02961	340	80	80	9,5	1200	1100	Type III
02962	500			11,5	1500	1400	
02963	700			14,5	1700	1600	
02964	840			16	1900	1800	
02965	1000			19,5	2100	1950	
02966	500	100	100	11	1600	1500	
02967	670			12,5	1850	1790	
02968	860			14,5	2100	2000	
02969	1000			17,5	2250	2150	
02970	1200			19	2450	2350	
02971	1500			23,5	2700	2550	
02972	610	120	120	12	1900	1750	
02973	1000			16	2650	2500	
02974	1500			21	3400	3200	
02975	2000			26	3950	3800	
02976	3000			36	4800	4550	
02977	4500			51	5400	5400	

Note:

All information about current-load are approximate values for a non-insulated design. The reducing factor for an insulated design depending on the application is between 15-20 %. We supply a non-insulated version as standard. Standard insulation material is PVC. Other insulation materials such as silicone, glass silk, shrink tubing etc. are also available on request.

When ordering please specify: Part-No., total length, if drilling is required, please specify either type or drilling pattern, if isolation is desired, please add isolated. For insulation other than PVC, please specify insulation material type. If the connectors are to be sealed splash-proof, please add the words insulated and splash proof sealed to your order text.

**Air cooled high current cables
made out of stranded copper cables**
with and without insulation,
in solderless pressed design

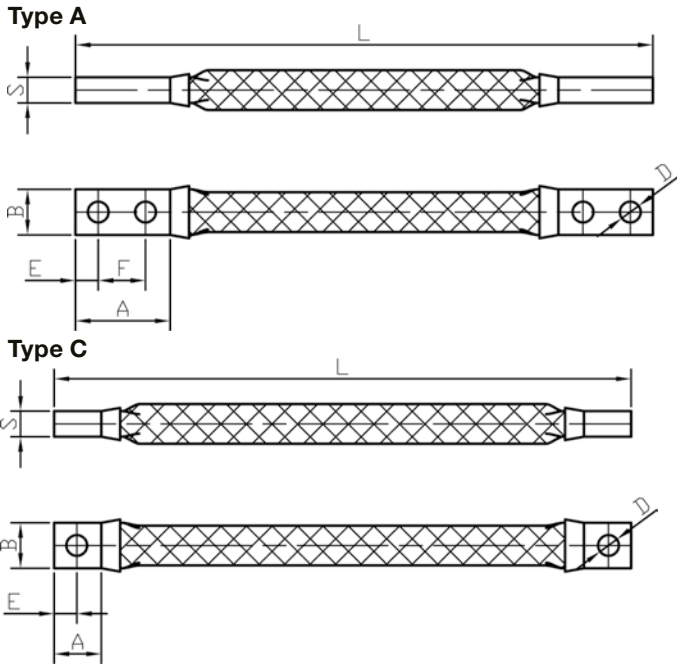

Standard design

Manufactured out of highly flexible round stranded copper cables with bare wires, wire-Ø 0,10 mm (standard) or 0,30 mm on request. With solderless pressed contact areas made out of uncoated, seamless E-Copper/copper-ETP tubes.

Contact areas

Contact areas rectangular with bending protection (standard). Without or bending protection only on one side on request. On request it is also possible to change the length of all contact areas.

Drilling

Standard drilling acc. to type A or C or acc. to your wishes.

Length

According to your wishes.

Insulation

Standard insulation material is a PVC-hose. Other materials like silicone, glass-fibre- or shrinking tubes etc. on request.

Special designs

In special design we deliver also connectors made out of tinned wires or with coated contact areas (tin-, nickel-, silver- or gold plated) or in coordination with your application according to your drawings, samples or wishes.

	Part-No.		Technical data									
	unin- sulated	PVC- insulated	cross-section mm ²	current- load	dimensions mm							L
					A	B	D	E	F	S		
Type A	15378	15448	70	300 A	30	15	7	7,5	15	8,5	According to your wishes.	
	15379	15449	95	360 A	40	20	9	10	20	8,2		
	15380	15450	120	420 A	40	20	9	10	20	10,0		
	15391	15451	150	480 A	50	25	11	12,5	25	11,5		
	15381	15452	185	570 A	50	25	11	12,5	25	13,5		
	15382	15453	240	670 A	60	32	11	16	32	12,8		
	15383	15454	300	780 A	80	40	14	20	40	13,3		
	15384	15455	400	950 A	80	40	14	20	40	15,5		
	15385	15456	500	1100 A	80	40	14	20	40	23,5		
	15386	15457	600	1250 A	80	55	14	20	40	18,8		
	15387	15458	700	1375 A	80	55	14	20	40	20,2		
	15388	15459	750	1450 A	80	55	14	20	40	21,8		
15389	15460	850	1550 A	80	55	14	20	40	22,3			
15390	15461	1000	1800 A	80	55	14	20	40	26,9			
Type C	15398	15465	70	300 A	15	15	7	7,5	-	8,5	According to your wishes.	
	15399	15466	95	360 A	20	20	9	10	-	8,2		
	15400	15467	120	420 A	20	20	9	10	-	10,0		
	15411	15468	150	480 A	25	25	11	12,5	-	11,5		
	15401	15469	185	570 A	25	25	11	12,5	-	13,5		
	15402	15470	240	670 A	32	32	11	16	-	12,8		
	15403	15471	300	780 A	40	40	14	20	-	13,3		
	15404	15472	400	950 A	40	40	14	20	-	15,5		
	15405	15473	500	1100 A	40	40	14	20	-	23,5		
	15406	15474	600	1250 A	40	55	14	20	-	18,8		
	15407	15475	700	1375 A	40	55	14	20	-	20,2		
	15408	15476	750	1450 A	40	55	14	20	-	21,8		
15409	15477	850	1550 A	40	55	14	20	-	22,3			
15410	15478	1000	1800 A	50	55	14	20	-	26,9			

Remark:

All information about current-load are approximate values for single laying of air cooled cables and ambient temperature + 35° C and a conductor temperature of circa + 70° C. The temperature of the conductor is in dependent on the installation, the application, the cooling, the ambient temperature etc. so that if necessary reducing factors are to be considered. The reducing factor for an insulated design depending on the application is between 15-20 %.

Air cooled high current cables made out of stranded copper cables

with and without insulation,
in solderless pressed design

Type A

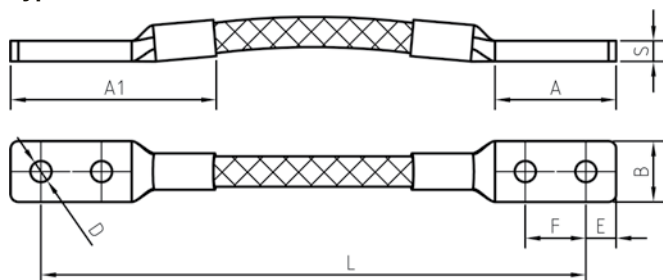

Type C

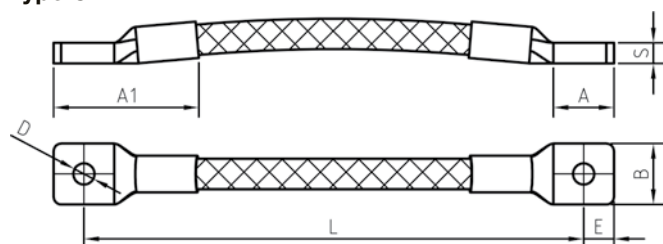

Standard design

Manufactured out of highly flexible round stranded copper cables with bare wires, wire-Ø 0,10 mm (standard) or 0,30 mm on request. With solderless pressed contact areas made out of uncoated, seamless E-Copper/copper-ETP tubes.

Contact areas

Contact areas shaped like a cable lug, so that two cables can also be mounted against each other on one connection bar.

Drillings

Standard drilling according to type A or C or according to your wishes.

Lengths

According to your wishes.

Insulation

Standard insulation material is a PVC-hose. Other materials like silicone, glass-fibre or shrinking tubes etc. on request.

Special designs

In special design we deliver also connectors made out of tinned wires or with coated contact areas (tin-, nickel-, silver- or gold plated) or in coordination with your application according to your drawings, samples or wishes.

	Part-No.		Technical data									
			cross-section mm ²	current- load	dimensions mm							
	unin- sulated	PVC- insulated			A	A ₁	B	D	E	F	S	L
Type A	14645	14700	70	300 A	30	50	15	7	7,5	15	8,5	According to your wishes.
	14646	14701	95	360 A	40	70	20	9	10	20	8,2	
	14647	14702	120	420 A	40	70	20	9	10	20	11,0	
	14648	14703	150	480 A	50	80	25	11	12,5	25	11,5	
	14649	14704	185	570 A	50	80	25	11	12,5	25	13,0	
	14650	14705	240	670 A	60	90	32	11	16	32	12,5	
	14651	14706	300	780 A	80	135	40	14	20	40	13,5	
	14652	14707	400	950 A	80	135	40	14	20	40	15,5	
	14653	14708	500	1100 A	80	135	40	14	20	40	22,0	
	14654	14709	600	1250 A	80	135	55	14	20	40	17,0	
	14655	14710	750	1450 A	80	135	55	14	20	40	21,0	
	14656	14711	850	1550 A	80	135	55	14	20	40	22,3	
14657	14712	1000	1800 A	80	135	60	14	20	40	24,5		
Type C	14660	14715	70	300 A	15	35	15	7	7,5	-	8,5	According to your wishes.
	14661	14716	95	360 A	20	50	20	9	10	-	8,2	
	14662	14717	120	420 A	20	50	20	9	10	-	11,0	
	14663	14718	150	480 A	25	55	25	11	12,5	-	11,5	
	14664	14719	185	570 A	25	55	25	11	12,5	-	13,0	
	14665	14720	240	670 A	32	62	32	11	16	-	12,5	
	14666	14721	300	780 A	40	95	40	14	20	-	13,5	
	14667	14722	400	950 A	40	95	40	14	20	-	15,5	
	14668	14723	500	1100 A	40	95	40	14	20	-	22,0	
	14669	14724	600	1250 A	40	95	55	14	20	-	17,0	
	14670	14725	750	1450 A	40	95	55	14	20	-	21,0	
	14671	14726	850	1550 A	40	95	55	14	20	-	22,3	
14672	14727	1000	1800 A	50	105	60	14	20	-	24,5		

Remark:

All information about current-load are approximate values for single laying of air cooled cables and ambient temperature + 35° C and a conductor temperature of circa + 70° C. The temperature of the conductor is in dependent on the installation, the application, the cooling, the ambient temperature etc. so that if necessary reducing factors are to be considered. The reducing factor for an insulated design depending on the application is between 15-20 %.



Standoff insulators

made out of polyester resin material
with double hexagon spanner flats and threaded steel inserts

Insulators made of glass-fibre reinforced polyester resin suitable for indoor applications. They are characterized by their assembly-friendly double hexagonal design. For this reason, both the upper and the lower part of the insulator have a hexagonal spanner flat, which are arranged offset to each other. It is therefore possible to install and remove the insulators quickly and safely, even in confined spaces. In terms of costs, this reduces the assembly effort to a minimum.

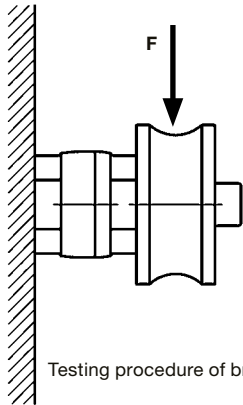
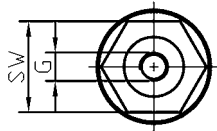
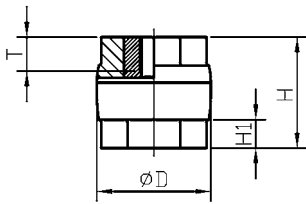

Testing procedure of breaking strength

Technical data of the material

• Density	DIN 53479	1,75 g/cm ³
• Flexural Resistance	DIN 53452/ISO R 178	120 N/mm ²
• Impact Resistance	DIN 53455/ISO R 527	70 N mm ²
• Impact Value	DIN 53453/ISO R179	45 KJm ²
• Long Term/ Operational Temperature	VDE 0304, Part 21/IEC 216	+ 130 ° C
• Rod Behaviour	VDE 0304, Part 3	Step BH 2 ≤ 10
• Behaviour in case of Fire	UL 94	V-0
• Surface Resistance	DIN 53482	10 ¹³ Ω
• Throughout Resistance		
Dielectric	DIN 53482	10 ¹⁴ Ω . cm
• Loss Factor	DIN 53483	< 0,02 tan/50 Hz
• Deposit Tracking	DIN IEC 112/VDE 0303, Part 1	CT 600
• Water Absorption	DIN 53495	< 50 mg/1 d
• Colour	-	brown

The values in the table have been determined with our own standards based on DIN 53451 and combined with the standards for the respective materials for test purposes.

Part-No.	Technical data										
	dimensions mm										weight
	D	H	G	SW	T	H ₁	PS/kV	BWS/kV	F/kN	Z/kN	kg/% pcs.
03068 S	30	30	M 6	24	8	9,5	5	0,75	3	6	5,70
03069 S			M 8								5,40
03070 S	30	40	M 6	24	10	10	5	1,00	4	8	7,30
03071 S	35	30	M 6	30	8	10	5	0,75	4	7	6,50
03072 S			M 8						5	8	6,10
03073 S	40	40	M 8	32	12	10,5	5	1,00	6	11	13,00
03074 S			M10		11						12,10
03075 S			M12		10						11,20
03080 S	40	50	M 8	32	12	10,5	10	1,50	5	11	16,50
13080 S			M10		15						16,50
03081 S			M12		13				7		13,80
13081 S	40	60	M 8	32	12	11	10	1,50	4	11	16,90
13082 S			M10		15						17,60
03078 S	50	40	M10	41	11	13	5	1,00	8	13	16,50
03079 S			M12		10				10		16,50
13083 S	50	50	M12	41	13	13,5	10	1,50	8	13	20,00
03084 S	50	60	M10	41	15	13,5	10	1,50	6	13	24,10
03085 S			M12		18				7		24,70
13084 S	60	60	M12	50	18	18,5	10	1,50	9	15	32,30
13085 S			M16		17				12	17	32,80

F = rated load on upper insulator edge PS = testing voltage
Z = tensile force BWS = operating voltage

Standoff insulators

made out of polyester resin material
with single hexagon spanner flat and threaded steel inserts

Standoff insulators manufactured out of a glass fibre reinforced polyester resin suitable for indoor applications. The characteristic of the material is in accordance with DIN Type 803. The compound is free of halogen with an excellent behaviour in case of fire (UL 94 V-0) and a very good strength of shape.

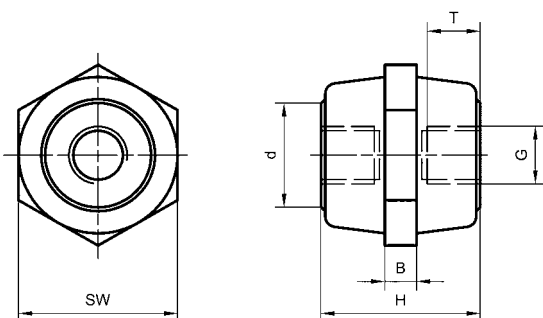

Technical data of the material

- Strength of shape ISO 75 > 250° C
- Behaviour in case of fire UL 94 Class V-0 at 3,2 mm
- Density ISO 1183 1,75 g/cm³
- Special throughout resistance IEC 60093 10¹⁵ Ohm
- Dielectric strength IEC 60243 20 kV/mm
- Deposit tracking IEC 60112 CTI 600
- Colour brown
- Temperature range - 40° C up to + 130° C

Part-No.	Technical data												
	H	SW	dimensions mm		d	B	Md/Nm	F/kN	Z/kN	D/kN	BWS/kV	PWS/kV	weight kg/% pcs.
06135	18	15	M 4	4,5	11	-	3,3	1,0	2	12	1,0	5	0,70
06138	20	20	M 5	5,5	14	5	5	1,3	3	20	1,0	5	1,20
06139	25	25	M 5	5,5	16	6	15	1,5	3	20	1,0	10	2,40
06140			M 6	8			15	1,5	5	35			2,40
06143	30	30	M 6	8	20	6	20	2,5	6	45	1,0	15	3,80
06144			M 8	10			40	3,0	12	60			5,40
06145			M10	11			50	4,0	12	60			6,60
06147	35	30	M 6	8	20	6	20	2,0	6	45	1,0	15	4,50
06148			M 8	10			40	3,5	12	60			6,00
06149			M10	11			50	4,0	16	75			7,00
06150	35	40	M 8	10	28	8	40	4,0	14	70	1,0	15	6,40
06151			M10	11			50	4,5	16	80			7,00
06152	40	30	M 6	8	20	6	20	1,5	6	45	2,0	20	5,00
06153			M 8	10			40	3,0	12	60			6,60
06154			M10	11			50	3,0	12	60			8,60
06156	40	40	M 8	10	28	8	50	5,0	14	90	2,0	20	10,00
06157			M10	14			90	8,0	20	100			12,20
06158			M12	12,5			100	9,0	22	120			13,50
06160	40	50	M 8	10	32	8	70	5,0	14	140	2,0	20	13,80
06161			M10	14			120	12,5	23	140			16,00
06162			M12	18			200	12,5	28	180			17,00
06165	50	40	M 8	10	28	10	50	5,0	14	90	3,0	25	12,00
06166			M10	14			90	5,0	20	100			14,00
06167			M12	18			100	6,0	22	120			16,00
06169	50	50	M 8	10	32	10	70	4,5	14	120	3,0	25	17,50
06170			M10	14			120	10,0	23	140			20,00
06171			M12	18			180	10,0	28	180			21,50
06172			M16	16			180	10,0	28	180			23,90
06174	60	40	M 8	10	28	8	50	4,0	14	90	3,0	25	14,00
06175			M10	14			90	6,0	20	100			16,00
06176			M12	18			120	6,0	20	100			18,00
06178	60	50	M10	14	32	10	120	9,0	23	140	3,0	25	23,00
06179			M12	18			200	11,0	28	180			25,00
06182	60	60	M12	18	40	12	200	12,0	28	220	3,0	25	33,00
06183			M16	21			300	15,0	32	240			35,00
06184			M20	22			300	16,0	37	240			38,60
06185	80	60	M10	14	40	12	200	11,0	32	220	3,0	25	41,00
06186			M12	18			300	15,0	37	240			43,00
06187			M16	21			300	15,0	37	240			45,00

Part-No. 06135 Cylindrical design without spanner flat

SW = wrench size
T = usable thread depth
F = rated load limit on upper insulator edge

PWS = testing voltage (AC)
Z = tensile force
D = compressive force

Md/Nm = permissible tightening torque
BWS = operating voltage

Standoff insulators made out of Polyamide

with single hexagon spanner flat and steel inserts

Standoff insulators manufactured out of reinforced, flame protected and heat stabilized Polyamide suitable for indoor applications. The compound is free of halogen and Phosphor. The material can be converted efficiently and is characterized by his excellent values for tensile strength (Z) and the rated load limit on the upper insulator edge (F). The differences to the design made out of glass fibre reinforced polyester resin are basically in the values for the behaviour in case of fire (class V2 to V-0) and the temperature range - 25° C up to + 120° C to - 40° C up to + 130° C.

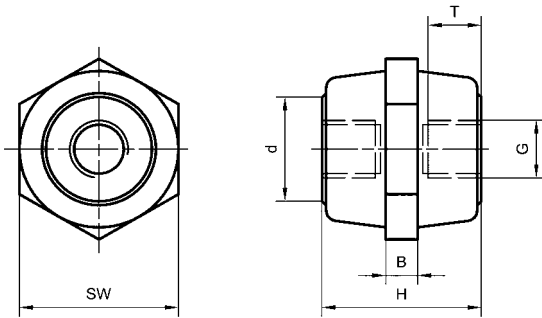

Technical data of the material

- | | | |
|-----------------------------|------------------------|------------|
| • Behaviour in case of fire | UL 94 | Class V2 |
| • Density | ISO 1183 | 1,36 g/cm³ |
| • Dielectric strength | IEC 60243-1 | 30 kV/mm |
| • Deposit tracking | IEC 60112 | CTI 475 |
| • Colour | nature | |
| • Temperature range | - 25° C up to + 120° C | |

Part-No.	Technical data												
	dimensions mm						Md/Nm	F/kN	Z/kN	D/kN	BWS/kV	PWS/kV	weight kg/% pcs.
	H	SW	G	T	d	B							
06100	18	15	M 4	4,5	11	3	3,3	1,0	2	12	1,0	5	0,60
06102	25	25	M 5	5,5	16	6	15	2,0	3	20	1,0	10	2,00
06103			M 6	8			15	2,0	5	35			2,00
06105	30	30	M 6	8	20	6	20	3,0	6	45	1,0	15	3,00
06106			M 8	10			40	4,0	12	60			5,00
06107			M10	11			50	8,0	14	60			6,40
06109	35	30	M 6	8	20	6	20	5,0	6	45	1,0	15	5,00
06110			M 8	10			40	5,0	12	60			6,00
06111			M10	11			50	5,0	16	75			6,00
06112	35	40	M 8	10	28	8	40	4,0	14	70	1,0	15	6,50
06113			M10	11			50	4,5	16	80			6,70
06114	40	30	M 6	8	20	6	20	1,5	6	45	2,0	20	7,40
06114/8			M 8	10			40	5,0	12	60			7,80
06115	40	40	M 8	10	28	8	50	7,0	14	90	2,0	20	8,00
06116			M10	14			90	10,0	28	100			10,00
06117			M12	12,5			100	12,0	22	120			10,00
06120	50	40	M 8	10	28	10	50	5,0	14	90	3,0	25	10,00
06121			M10	14			90	5,0	20	100			12,00
06122			M12	18			100	6,0	22	120			14,00
06125	50	50	M10	14	38	10	120	10,0	23	140	3,0	25	18,00
06126			M12	18			160	14,0	28	180			19,50
06127			M16	16			200	18,0	29	180			21,10
06129	60	40	M 8	10	28	8	50	4,0	14	90	3,0	25	12,00
06130			M10	14			90	6,0	20	100			14,00
06131			M12	18			120	6,0	20	100			14,80

SW = wrench size
 T = usable thread depth
 F = rated load limit on upper insulator edge

PWS = testing voltage (AC)
 Z = tensile force
 D = compressive force

Md/Nm = permissible tightening torque
 BWS = operating voltage

Bimetallic sheets and bimetallic washers

Bimetallic sheets

Bimetallic sheets consist of copper clad aluminium sheets in a 70/30 ratio (70 % aluminium and 30 % copper). Since the joint between the two metals is located inside the sheets air and moisture cannot enter. With this material, as an intermediate layer, a contact safe and corrosion-protected connection of copper and aluminium is possible. In addition to the bimetallic sheets and washers, we also supply cut offs with and without holes suitable for your applications.



Part-No.	Technical data				weight kg/pcs.
	dimensions mm				
	length	width	thickness		
02670	2000	500	1		4,70
02671			1,5		7,00
02672			2		9,35

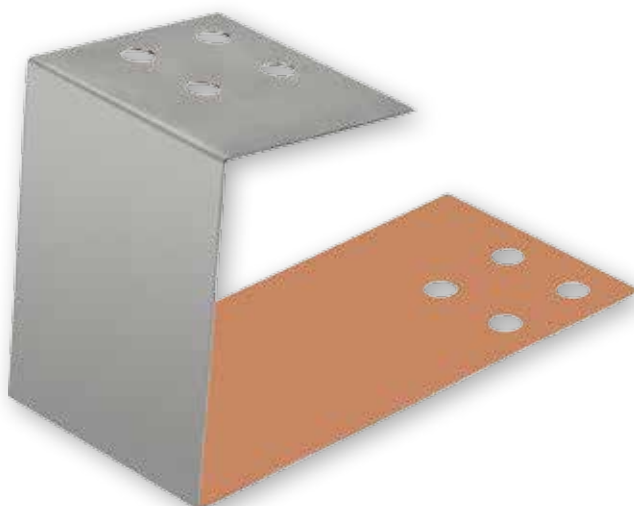

Cuttings from bimetallic sheets

We manufacture finished sheet metal parts from our bimetallic sheets with a sheet thickness of 1/1,5 or 2 mm according to customer requirements. Regardless of whether with or without holes or in edged design, the most diverse components are possible. We also produce small series or individual parts without any problems.

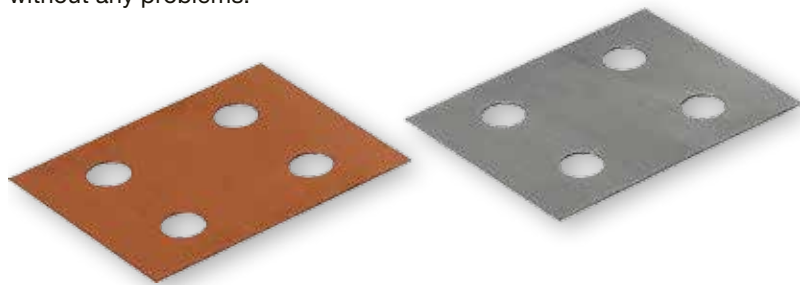

Bimetallic washers

Part-No.	Technical data				weight kg/% pcs.
	dimensions mm				
	for thread M	outside- Ø	hole- Ø	S	
13295	3	8	3,5	1	0,02
13296	4	10	4,5	1	0,03
13297	5	12	5,5	1	0,05
02675	6	15	6,5	1	0,07
02676	8	18	8,5	1	0,09
02677	10	22	10,5	1,5	0,18
02678	12	25	13	2	0,68
02679	12	28	13	2	0,44
02680	16	35	17	2	0,86

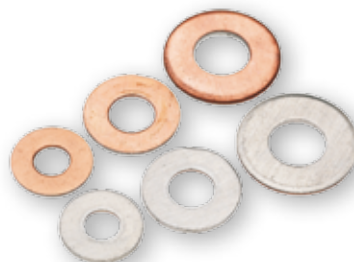

Hexagon head screws DIN 931/DIN 933

Material: stainless-steel A2

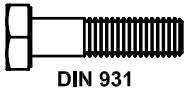

DIN 931



DIN 933

Bolt length mm	Part-No. of the screws						
	M5	M6	M8	M10	M12	M16	M20
30	53101	53140	-	-	-	-	-
35	53102	53141	53180	-	-	-	-
40	53103	53142	53181	53220	-	-	-
45	53104	53143	53182	53221	53260	-	-
50	53105	53144	53183	53222	53261	-	-
55	-	53145	53184	53223	53262	53301	-
60	-	53146	53185	53224	53263	53302	-
65	-	-	53186	53225	53264	53303	53341
70	-	-	53187	53226	53265	53304	53342
80	-	-	53188	53227	53266	53305	53343
90	-	-	53189	53228	53267	53306	53344
100	-	-	53190	53229	53268	53307	53345
110	-	-	-	-	53269	53308	53346
120	-	-	-	-	53270	53309	53347

Remark: When ordering, please indicate the desired DIN. If a version is desired in A4 stainless-steel, please indicate A4 in the order.

Threaded Rods

Material: stainless-steel A2/A4 or brass

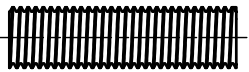

Part-No.			Technical data	
Material: A2	Material: A4	Material: brass	dimensions mm	
			Thread	Rod length
17980	18030	18080	M 3	1 m
17985	18035	18085	M 4	1 m
17990	18040	18090	M 5	1 m
17995	18045	18095	M 6	1 m
18000	18050	18100	M 8	1 m
18005	18055	18105	M10	1 m
18010	18060	18110	M12	1 m
18015	18065	18115	M16	1 m
18020	18070	18120	M20	1 m

Clamping discs, DIN 6796

Material: spring steel

Surface: ZN 12 M + Passivation

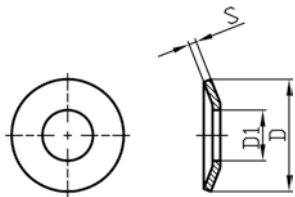

Part-No.	Technical data				
	dimensions mm				package unit/pcs.
for bolt	D ₁	D	S		
18350	M 3	3,2	7	0,5	1000
18355	M 4	4,3	9	0,8	1000
18360	M 5	5,3	11	1	1000
18365	M 6	6,4	14	1,2	1000
18370	M 8	8,4	18	2	500
18375	M10	10,5	23	2	100
18380	M12	13	29	2,5	100
18390	M16	17	39	3,5	100
18395	M20	21	52	5,5	100

Discs DIN 7349

Material: stainless-steel A2

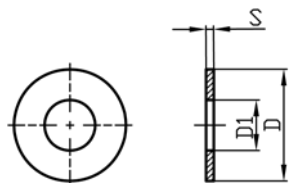

Part-No.	Technical data				
	dimensions mm				package unit/pcs.
for bolt	D ₁	D	S		
18400	M 3	3,2	9	1	500
18402	M 4	4,2	12	1,6	500
18404	M 5	5,3	15	2	500
18406	M 6	6,4	17	3	500
18408	M 8	8,4	21	4	500
18410	M10	10,5	25	4	200
18412	M12	13,0	30	6	100
18414	M16	17,0	40	6	100
18416	M18	19,0	44	8	50
18418	M20	21,0	44	8	50

Note: If desired available in stainless-steel A4 too

Hexagon nuts DIN 934

Material: stainless-steel A2

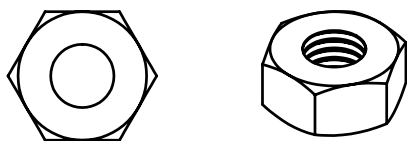

Part-No.	Technical data	
	thread	package unit/pcs.
18150	M 3	500
18155	M 4	500
18160	M 5	500
18165	M 6	100
18170	M 8	100
18175	M10	100
18180	M12	100
18185	M16	100
18190	M20	100

Note: If desired, also available in stainless-steel A4.

Washers

Material: stainless-steel A2



Part-No. DIN 125	Part-No. DIN 9021	Technical data			
		for bolt	outside-Ø		package unit/pcs.
			DIN 125	DIN 9021	
18200	18241	M 3	7	9	500
18205	18242	M 4	9	12	500
18210	18243	M 5	10	15	500
18215	18244	M 6	12,5	18	500
18220	18245	M 8	17	25	500
18225	18246	M10	21	30	100
18230	18247	M12	24	40	100
18235	18248	M16	30	50	100
18240	18249	M20	37	60	100

Note: If desired, also available in stainless-steel A4.

Spring washers DIN 127 B

Material: stainless-steel A2



Part-No.	Technical data		
	for bolt	hole-Ø mm	package unit/pcs.
18250	M 3	3,1	500
18255	M 4	4,1	500
18260	M 5	5,1	500
18265	M 6	6,1	500
18270	M 8	8,2	100
18275	M10	10,2	100
18280	M12	12,2	100
18285	M16	16,2	100
18290	M20	20,2	50

Note: If desired, also available in stainless-steel A4.

Serrated washers DIN 6798

Material: bronze



Part-No.	Technical data		
	for bolt	hole-Ø mm	package unit/pcs.
18300	M 3	3,2	500
18305	M 4	4,3	500
18310	M 5	5,3	500
18315	M 6	6,4	500
18320	M 8	8,4	500
18325	M10	10,5	100
18330	M12	12,5	100
18335	M16	18,5	100

Note: If desired, also available in stainless-steel A4.

Insulating grommets

Material: epoxy glass hard resin

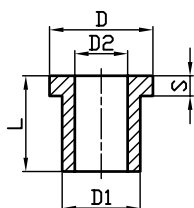

Part-No.	Technical data					
	for bolt	L	D	dimensions mm		
			D ₁	D ₂	S	
53450	M 8	32	20	14	9	4
53455	M10	32	23	16	11	4
53460	M12	34	25	18	13	6
53465	M16	32	32	22	17	6
53470	M20	38	38	27	21	8

Note: These insulating grommets are used for insulating fastening bolts from the tank or other metal parts, e.g. for contact block fastening. The material epoxy glass hart resin is well suited in terms of temperature resistance as well as its resistance to pressure as, e.g. in the use of electroplating plants.

Cup wing nuts and bolts



Part-No.	Technical data				
	dimensions mm				weight kg/% pcs.
	thread	wing-Ø	cup-Ø	Material	
cup wing nuts					
17780	M 8	40	40	A4 stainless steel	3,90
17785	M 10	50	40	A4 stainless steel	6,50
17790	M 12	65	50	A4 stainless steel	11,50
53500	M 8	40	35	brass	5,00
53505	M 10	40	35	brass	5,10
cup wing bolts					
17815	M 8 x 35	40	40	A4 stainless steel	5,10
17820	M 10 x 35	50	40	A4 stainless steel	8,00
17825	M 12 x 35	65	40	A4 stainless steel	10,80
53485	M 10 x 25	45	40	brass	15,50

Note: Also suitable as clamping elements for electroplating racks or anodes.

Small contacts

Material: Brass resp. E-copper

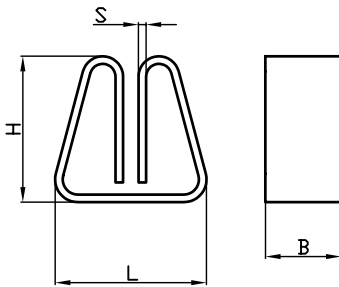

Part-No.	Technical data						
	for busbar	L	B	H	S	Material	weight kg/pcs.
51330	25 x 4	21	23	43	2	brass	0,06
51335	40 x 5	38	38	67	3	brass	0,25
51340	50 x 5	64	40	67	5	E-copper	0,50

Note: Cold formed designs without connection holes. Also available drilled or with surface finishing on request.

High temperature resistant copper paste and cleaning sprays



Part-No.	Product name	content	description
Pastes			
02770	Copper paste	1 kg	Electrically conductive soft smooth assembly paste based on semi-synthetic basis oil and particularly pure copper powder with very small particle size. Good adhesion to all metals, vapour and water resistant, non-drip, temperature stable (temperature range - 30° C up to + 1100° C), corrosion-protective and well-sealing. Particularly suitable for connections and soiling that are subject to high thermal stress or corrosive influences.
Cleaning sprays			
11260	Spray Contactclean	400 ml	Eliminates oxide and sulphide build up on metal contact surfaces of all types and builds a long lasting lubrication and corrosion protection.
11262	Spray Spray wash	400 ml	Removes contamination and grease as well as oxid layers produced by using the Contactclean spray. Good wash and flow properties allow contamination to be simply rinsed away.
11264	Degreaser spay	400 ml	Ensures safe and quick removal of grease and oil, wax and other heavy soiling. Also has a moisture and water displacing effect.

Technical appendix

History, selection criteria, current loads and security requirements when using our contact systems and current transmission elements

History and development of our contact systems

The spring loaded finger and bolt contact saddle systems listed in this catalogue (catalogue pages 7-15 as well as 19-20) were developed by the druseidt company as early as 1960s and 1970s in order to transmit the electroplating current to the product-carriers in automated electroplating and anodizing plants. The contact pressure in all these systems depends on the spring strength used. It is therefore severely limited, since if the springs are too strong, the product carriers can no longer retract into the contact saddle under their own weight.

In order to increase the contact pressure, druseidt developed various pneumatically operated contact systems years ago, both as finger and plate contacts (catalogue pages 16 + 17 resp. 37-41). With these systems, the contact pressure is limited by the piston surfaces or the pressure force of the pneumatic cushions used. In relation to the contact surfaces, however, it is also far below that of a comparable screw connection carried out in accordance with the DIN standards. Due to the further development of the plant systems and their control technology with extremely short cycle times and very short break/cooling down times or processes with extremely long bath times, many older or simply designed contact systems are overtaxed today, as they were developed at the time for other operating conditions, current or cooling down times.

For this reason, the druseidt company has further developed both the finger and the bolt contact saddle technology and adapted then to the current requirements of plant technology. Completely new systems of pneumatic or hydro-pneumatic contact pressure generation have been developed, which make it possible to achieve a previously unattainable contact pressure for contact saddles inside of electroplating plants (catalogue pages 21-25 resp. 27-36). This minimized the electrical resistance and due to other improvements, the contact saddles were optionally adapted to today's operating conditions. Such systems are particularly suitable for long continuous current times and 3-shift operation.

Theoretical basis on the subject of electrical connection and contact resistance

The quality of an electrical connection depends on the material, cross-section and dimension of the contact surfaces as well as on the contact pressure and the surface quality of the contact points. These criteria influence the electrical contact resistance and thus the quality and service life of the connection. The electrical contact resistance of a clamp or screw connection decreases up to a certain limit with increasing contact pressure.

Demands to contact saddles and current transfer elements

Contact saddles and current transfer elements must be selected under the condition that by using the components in accordance with the regulations or requirements no unacceptable risks are created for life and health of persons as well as a damaging of objects. To guarantee these demands, it is absolutely necessary, to check and analyze possible risks, source of errors, and rest risks even when planning or designing plants or products. All components of current transfer must be so calculated that they are sufficient dimensioned for all possible load (current as well as voltage) which can be occurred inside of the planned application. Particularly by existing limit conditions it is necessary to take the values of the current rates or voltages fixed in national or international regulations into consideration. Thus, all contact systems, components and current transmission elements listed in this catalogue are only intended for normal, customary electroplating or anodizing operation. All switching operations may only be carried out in a de-energized state without load. For other applications as well as in all cases of doubt, consultation with us is absolutely necessary.

Influencing variables with regard to the dimensioning of contact systems in the area of electroplating and anodizing plants

As already explained on page 4 of this catalogue, there is unfortunately no single contact, that is equally suitable for all systems. It is also often not possible or sensefull to use a standard catalogue solution and the contact saddles must be adapted to the requirements of the application. Influencing factors with regard to the selection of contact systems and the required dimensioning/current load are therefore:

- The current load
- The cycle time/duration of the current load
- The current feed (symmetrical/unsymmetrical)
- Weight and dimension of the product carriers
- Shape and dimensions of the contact points of the product carriers
- Expected chemical influences and contamination
- Possible mechanical stress
- Any existing bath movements
- Available installation space

Current load of our contact systems

The current dimensioning of our contact systems must take above-mentioned possible influencing variables into account. This means that due to the application and environmental conditions, a contact with a higher current rating than the actual flow must often be provided. In particular the cycle time/duration of the current flow must be considered taking into account cooling down times, contamination, mechanical load and current injection. So we recommend our further developed contact systems of the catalogue pages 21-25 resp. 27-36 especially for systems with short cycle times of the product carriers and consequently hardly any or no cooling down times as well as processes with long current flow or multi shift operated systems (see also History/Development of our contact systems) or to dimension our other contact saddles with a current higher than the specified maximum current for safety reasons. With pleasure we'll advise you on your application.

Installation of our contact systems/current transfer elements

When our contact systems are delivered, assembly instructions are included with the consignment. For the design of the screw connections, we recommend that the guide lines of DIN 43673 Part 1 busbars, drill-holes and screw connections be taken into account. Stainless steel A2/A4 should be used as the material of the bolting elements. When screwing copper to aluminium components, bimetallic material should be used as an intermediate layer (see also our catalogue page 75). We will be pleased to send you our detailed screw connection instructions on request, also applicable for busbars and flexible connectors.

Maintenance and servicing of contact systems

Contact systems are electrical equipment that require continuous control, maintenance and servicing. The intervals and the activities to be carried out depend on the individual conditions of use. Pay particularly attention to soiling and damaged parts. Dirty contact saddles should be cleaned immediately. The use of additional mounted protective covers out of stainless steel or an additional use of our cleaning systems offered on the catalogue pages 26, 43-48 as well as 78 support your efforts here. All druseidt contact systems are manufactured according to the modular principle and we offer corresponding spare and replacement parts. Only use original spare parts and do not change the setting of preset contact saddles without prior consultation with us. Only functional contact systems guarantee low-loss operation of your system and avoid system down times. We are happy to support you with your applications here as well.

Table for the current load of copper busbars
acc. to DIN 43671

width x thickness mm	material	continuous current in A															
		AC up to 60 Hz								DC/AC up to 16 2/3 Hz							
		painted				bare				painted				bare			
		number of busbars				number of busbars				number of busbars				number of busbars			
1	2	3	4	1	2	3	4	1	2	3	4	1	2	3	4		
I	II	III	II II	I	II	III	II II	I	II	III	IIII	I	II	III	IIII		
12 x 2		123	202	228		108	182	216		123	202	233		108	182	220	
15 x 2		148	240	261		128	212	247		148	240	267		128	212	252	
15 x 3		187	316	381		162	282	361		187	316	387		162	282	365	
20 x 2		189	302	313		162	264	298		189	302	321		162	266	303	
20 x 3		237	394	454		204	348	431		237	394	463		204	348	437	
20 x 5		319	560	728		274	500	690		320	562	729		274	502	687	
20 x 10		497	924	1320		427	825	1180		499	932	1300		428	832	1210	
25 x 3		287	470	525		245	412	498		287	470	536		245	414	506	
25 x 5		384	662	869		327	586	795		384	664	841		327	590	794	
30 x 3		337	544	593		285	476	564		337	546	608		286	478	575	
30 x 5		447	760	944		379	672	896		448	766	950		380	676	897	
30 x 10		676	1200	1670		573	1060	1480		683	1230	1630		579	1080	1520	
40 x 3	E-Cu F30/ Cu-ETP	435	692	725		366	600	690		436	696	748		367	604	708	
40 x 5	4/4 hard	573	952	1140		482	836	1090		576	966	1160		484	848	1100	
40 x 10		850	1470	2000	2580	715	1290	1770	2280	865	1530	2000		728	1350	1880	
50 x 5		697	1140	1330	2010	583	994	1260	1920	703	1170	1370		588	1020	1300	
50 x 10		1020	1720	2320	2950	852	1510	2040	2600	1050	1830	2360		875	1610	2220	
60 x 5		826	1330	1510	2310	688	1150	1440	2210	836	1370	1580	2060	696	1190	1500	1970
60 x 10		1180	1960	2610	3290	985	1720	2300	2900	1230	2130	2720	3580	1020	1870	2570	3390
80 x 5		1070	1680	1830	2830	885	1450	1750	2720	1090	1770	1990	2570	902	1530	1890	2460
80 x 10		1500	2410	3170	3930	1240	2110	2790	3450	1590	2730	3420	4490	1310	2380	3240	4280
100 x 5		1300	2010	2150	3300	1080	1730	2050	3190	1340	2160	2380	3080	1110	1810	2270	2960
100 x 10		1810	2850	3720	4530	1490	2480	3260	3980	1940	3310	4100	5310	1600	2890	3900	5150
120 x 10		2110	3280	4270	5130	1740	2860	3740	4500	2300	3900	4780	6260	1890	3390	4560	6010
160 x 10		2700	4130	5360	6320	2220	3590	4680	5530	3010	5060	6130	8010	2470	4400	5860	7110
200 x 10		3290	4970	6430	7490	2690	4310	5610	6540	3720	6220	7460	9730	3040	5390	7150	9390

Remark: Continuous currents for busbars Cu-ETP/E-Cu according to the DIN regulations for rectangular bars in interior systems at + 35° C air temperature and + 65° C bar temperature and vertical position, bar packages with spaces like the bar thickness respectively minimum 50 mm by laying of

4 busbars or when working with AC-current with a main distance of > 0,8 x main conductor distance (measured middle to middle of the bars). Values for a charged ambient temperature and reducing factors for changed applications are contained in the DIN 43671.

Material indications for copper busbars

indication	tensile strength min. N/mm ²	conductivity by + 20° C in Siemens	specific resistance by + 20° C $\frac{\Omega \times \text{mm}^2}{\text{m}}$	density kg/dm ³	
E-Cu F20	Cu-ETP soft	200	57	0,01754	8,9
E-Cu F25	Cu-ETP half hard	250	56	0,01786	8,9
E-Cu F30	Cu-ETP 4/4 hard	300	56	0,01786	8,9
E-Cu F37	Cu-ETP very hard	360	55	0,01818	8,9

Table for the current load of aluminium busbars

acc. to DIN 43670

width x thickness mm	material	continuous current in A															
		AC up to 60 Hz								DC/AC up to 16 2/3 Hz							
		painted				bare				painted				bare			
		number of busbars				number of busbars				number of busbars				number of busbars			
1	2	3	4	1	2	3	4	1	2	3	4	1	2	3	4		
I II III II II				I II III II II				I II III IIII				I II III IIII					
12 x 2	E-Al F13	97	160	178		84	142	168		97	160	183		84	142	171	
15 x 2		118	190	204		100	166	193		118	190	210		100	166	197	
15 x 3		148	252	300		126	222	283		148	252	305		126	222	286	
20 x 2		150	240	245		127	206	232		150	240	252		127	206	237	
20 x 3		188	312	357		159	272	337		188	312	364		159	272	342	
20 x 5		254	446	570		214	392	537		254	446	576		214	392	539	
20 x 10		393	730	1060		331	643	942		393	733	1020		331	646	943	
25 x 3	228	372	412		190	322	390		228	372	422		191	322	396		
25 x 5	305	526	656		255	460	619		305	528	663		255	460	622		
30 x 3	267	432	465		222	372	441		268	432	477		222	372	449		
30 x 5	356	606	739		295	526	699		356	608	749		296	528	703		
30 x 10	536	956	1340		445	832	1200		538	964	1280		447	839	1180		
40 x 3	E-Al-F10	346	550	569		285	470	540		346	552	586		285	470	552	
40 x 5		456	762	898		376	658	851		457	766	915		376	662	862	
40 x 10		677	1180	1650	2190	557	1030	1460	1900	682	1200	1570		561	1040	1460	
50 x 5		556	916	1050	1580	455	786	995	1520	558	924	1080		456	794	1020	
50 x 10		815	1400	1940	2540	667	1210	1710	2210	824	1440	1850		674	1250	1730	
60 x 5		655	1070	1190	1820	533	910	1130	1750	658	1080	1240	1610	536	924	1170	1530
60 x 10		951	1610	2200	2870	774	1390	1940	2480	966	1680	2130	2810	787	1450	2000	2650
80 x 5	851	1360	1460	2250	688	1150	1400	2180	858	1390	1550	2010	694	1180	1470	1920	
80 x 10	1220	2000	2660	3460	983	1720	2380	2990	1250	2150	2670	3520	1010	1840	2520	3340	
100 x 5	1050	1650	1730	2660	846	1390	1660	2580	1060	1710	1870	2420	858	1450	1780	2320	
100 x 10	1480	2390	3110	4020	1190	2050	2790	3470	1540	2630	3230	4250	1240	2250	3060	4050	
100 x 15	1800	2910	3730	4490	1450	2500	3220	3880	1930	3380	4330	5710	1560	2900	4070	5400	
120 x 10	1730	2750	3540	4560	1390	2360	3200	3930	1830	3090	3770	4940	1460	2650	3580	4730	
120 x 5	E-Al F6,5	2090	3320	4240	5040	1680	2850	3650	4350	2280	3950	5020	6610	1830	3390	4740	6280
160 x 10		2220	3470	4390	5610	1780	2960	4000	4820	2380	4010	4820	6300	1900	3420	4590	6060
160 x 10		2670	4140	5230	6120	2130	3540	4510	5270	2960	5090	6370	8380	2370	4360	6040	8000
200 x 10		2710	4180	5230	6660	2160	3560	4790	5710	2960	4940	5880	7680	2350	4210	5620	7400
200 x 10	3230	4950	6240	7190	2580	4230	5370	6190	3660	6250	7740	10160	2920	5350	7370	9750	

Remark: Continuous currents for aluminium busbars according to the DIN regulations for rectangular bars in interior systems at + 35° C air temperature and + 65° C bar temperature and vertical bar position, bar packages with spaces like the bar thickness respectively minimum 50 mm

by laying of 4 busbars or when working with AC-current with a main distance of $> 0,8 \times$ main conductor distance (measured middle to middle of the bars). Values for a changed ambient temperature and reducing factors for changed applications are contained in the DIN 43670.

Material indications for aluminium busbars

indication		tensile strength min. N/mm ²	conductivity by + 20° C in Siemens	specific r esistance bei + 20° C $\frac{\Omega \times \text{mm}^2}{\text{m}}$	density kg/dm ³
E-Al F6,5/7	EN-AW 1350 A	65/70	34 - 35	0,0278	2,7
E-Al F8	EN-AW 1350 A	80	34 - 35	0,0286	2,7
E-Al F10	EN-AW 1350 A	100	33 - 34	0,0286	2,7

**Comparison table of the new material indications acc. to DIN EN 13599 - 13602
and following to the older indications to DIN 1751/1791 resp. DIN 40500**

material indication			
DIN EN 13599 - 13602		DIN 1751: 1973 - 06, DIN 1791: 1973 - 06, DIN 40500: 1980 - 04 ^a	
symbol	material-number	symbol	material-number
Cu-ETP1	CW003A	-	-
Cu-ETP	CW004A	E-Cu58	2.0065
Cu-FRHC	CW005A	E-Cu58	2.0065
Cu-OF	CW008A	OF-Cu	2.0040
CuAg0,10	CW013A	CuAg0,1	2.1203
CuAg0,10P	CW016A	CuAg0,1P	2.1191
CuAg0,10(OF)	CW019A	-	-
Cu-PHC	CW020A	SE-Cu ^b	2.0070 ^b
Cu-HCP	CW021A	SE-Cu ^c	2.0070 ^c

- With regard to the non-listed materials in our table, contained in the older norms take a look at DIN EN 1652:1998-03. An overall view about materials and products is contained in DIN V 17900:1999-03.
- If the conductivity is min. 58 m/Ω x m² and the content of copper has a min. value of 99,95 % by using of P for deoxidation.
- If content of copper has a min. value of 99,95 % by using P for deoxidation.

Table for the weight of copper busbars

width mm	weight per meter in kg/thickness mm									
	2	3	4	5	6	8	10	15	20	25
10	0,180	0,270	0,360	0,450	0,540	0,720	0,890	-	-	-
12	0,220	0,320	0,430	0,540	0,640	0,860	1,070	-	-	-
14	0,250	0,380	0,500	0,630	0,750	1,000	1,250	-	-	-
15	0,270	0,400	0,540	0,670	0,810	1,070	1,340	2,020	-	-
20	0,360	0,540	0,720	0,890	1,070	1,430	1,780	2,700	3,600	-
25	0,450	0,670	0,890	1,120	1,340	1,780	2,230	3,370	4,500	5,560
30	0,540	0,800	1,070	1,330	1,610	2,140	2,670	4,050	5,400	6,700
35	0,630	0,930	1,250	1,560	1,870	2,500	3,120	4,720	6,300	7,850
40	0,710	1,070	1,430	1,780	2,140	2,850	3,560	5,400	7,200	8,960
45	0,800	1,200	1,610	2,000	2,410	3,210	4,000	6,080	8,100	10,090
50	0,890	1,340	1,780	2,220	2,670	3,560	4,450	6,750	9,000	11,200
60	1,070	1,600	2,140	2,670	3,210	4,280	5,340	8,100	10,800	13,500
70	1,250	1,870	2,500	3,110	3,740	4,980	6,230	9,450	12,600	15,700
80	1,430	2,140	2,850	3,560	4,280	5,690	7,120	10,800	14,400	17,920
90	1,600	2,410	3,210	4,000	4,810	6,400	8,010	12,150	16,200	20,160
100	1,780	2,670	3,560	4,450	5,340	7,190	8,900	13,500	18,000	22,300
110	1,960	2,940	3,920	4,900	5,880	7,840	9,800	14,850	19,800	24,640
120	2,130	3,200	4,270	5,240	6,400	8,550	10,680	16,200	21,600	26,900
130	2,310	3,490	4,630	5,780	6,940	9,250	11,570	17,550	23,400	29,920
140	2,490	3,740	4,980	6,220	7,470	9,960	12,460	18,900	25,200	31,360
150	2,670	4,000	5,340	6,670	8,010	10,460	13,350	20,250	27,000	33,600
160	2,850	4,270	5,700	7,120	8,550	11,740	14,400	21,600	28,800	35,800
200	3,560	5,240	7,120	8,900	10,640	14,380	17,800	27,000	36,000	44,800

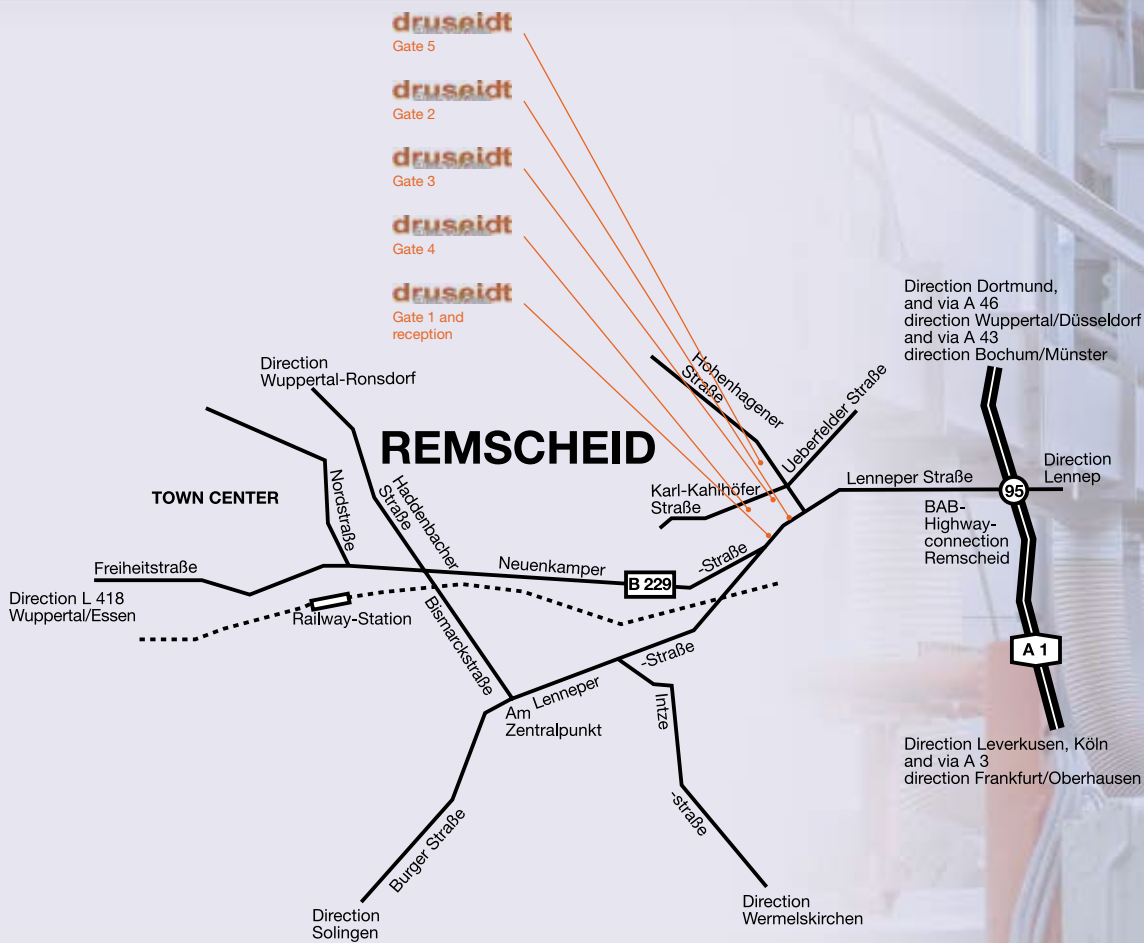

Paul Druseidt
Elektrotechnische Spezialfabrik GmbH & Co. KG

P.O. Box 10 02 25
42802 Remscheid
Germany

Gate 1: Neuenkamper Straße 105
Gate 2: Lenneper Straße 131
Gate 3: Karl-Kahlhöfer-Straße 9
Gate 4: Karl-Kahlhöfer-Straße 11
Gate 5: Hohenhagener Straße 15

42855 Remscheid
Germany

Phone: +49 (21 91) 93 52-0
Telefax: +49 (21 91) 93 52-150
http: www.druseidt.de
E-Mail: info@druseidt.de

Please order also our detailed catalogues to the following subjects:

- 1 Professional installation- and electrical connection technique for craft, industry and high current application
- 2 Flexible air and watercooled connectors and cables for Hi-Tech-applications
- 4 Busbars, non-ferrous metal working and accessories